

IMPORTANT SAFEGUARDS

Use basic safety precautions when working with electrical equipment. READ AND FOLLOW ALL SAFETY INSTRUCTIONS

1.

To prevent high voltage from being present on the purple and blue output leads prior to installation. The EMG-1AC Series connector must be open. Join the unit connector after the EMG-1AC Series has been installed and before the AC power is supplied.

2.

The series may be used to the LED luminaires in form below.

MODEL	COMPANY NAME	OPTICAL PARAMETER REQUIREMENT	MAXIMUM MOUNTING HEIGHT	SUPPORT WEIGHT
ESL-EMG-1AC-8W-xy	ESL VISION	580lm	20 Feet	2.4 Pounds
ESL-EMG-1AC-16W-xy	ESL VISION	1,360lm	20 Feet	2.87 Pounds
ESL-EMG-1AC-25W-xy	ESL VISION	2,125lm	28 Feet	3.3 Pounds

3.

Make sure all connections are in accordance with the National Electrical Code and/or any local regulations.

4.

To reduce the risk of electrical shock, disconnect both normal and auxiliary power supplies and unit connector of the EMG-1AC Series before servicing.

5.

An AC power source (100-277 VAC, 50/60Hz) ahead of any wall switch is required to provide battery charging current.

6.

Do not install near gas or electric heaters.

7.

This product is for use with indoor or damp locations where ambient temperature is (32°F - 122°F). It is not suitable for wet or hazardous locations.

DO NOT USE OUTDOORS

For use with grounded, UL Listed, damp location rated, indoor fixtures and case should be grounded.

The drivers are intended for standard locations and for permanent installation into one or more listed emergency luminaires.

This equipment has not been tested for use in an air handling fixture. Do not use in heated air outlets or hazardous locations.

8.

This is a sealed unit. Integral battery is not replaceable. Replace the entire unit when necessary.

9.

The use of accessory equipment is not recommended by the manufacturer. It may cause unsafe operating conditions.

10.

Servicing should be performed by a qualified service professional.

11.

Equipment should not be mounted in locations and at heights where it could be subjected to tampering by unauthorized personnel. Indicator light should be mounted in a easily visible location.

12.

Equipment only for use as a LED lighting emergency backup. Do not use this equipment for anything other than it's intended use.

13.

The weight of the equipment should be considered before installation.

SAVE THESE INSTRUCTIONS



This product contains a rechargeable lithium battery. THE BATTERY MUST BE RECYCLED OR DISPOSED OF PROPERLY TO PREVENT FIRE.

INSTALLATION INSTRUCTIONS



CAUTION: Before installing make certain the AC power is off and the LED lamp emergency backup unit connector is disconnected.

NOTE: Make sure that the necessary branch circuit wiring is available. An unswitched source of power is required. The unswitched and switched power source must be fed from same branch circuit.

MOUNTING OPTION 1

Emergency backup separate of fixture with flexible conduit.

The T-BAR mounting bracket assembly is sold separately. Please contact us at info@eslvision.com for more information.

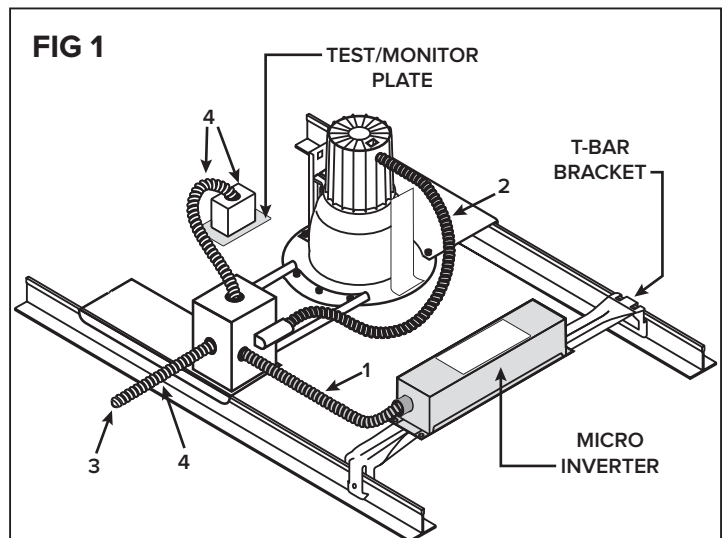

1. Flexible conduit (supplied) to connect AC driver wires.
2. Existing conduit to run existing wires to lamp holder.
3. AC line in.
4. Conduit and junction box (not supplied).

MOUNTING OPTION 2

Emergency backup inside fixture without flexible conduit.

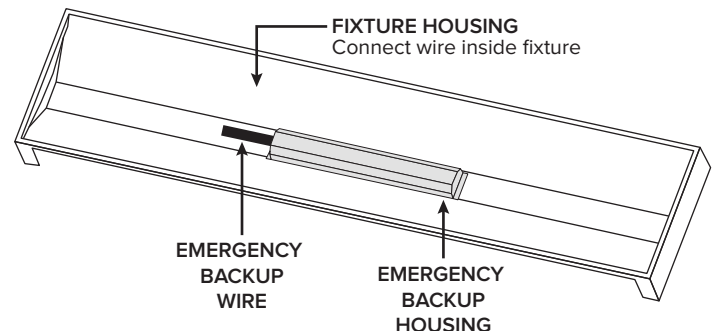

MOUNTING OPTION 3

Emergency backup outside of fixture without flexible conduit.

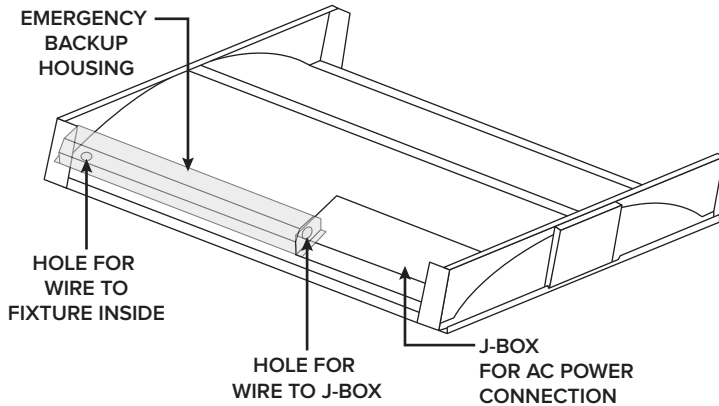

INSTALLING THE EMERGENCY EQUIPMENT

NOTE:

- The EMG-1AC Series will be located between the AC power sources and the AC driver as shown in wiring diagram section of instructions.
- The EMG-1AC Series may be installed in close proximity to the fixture or remote from the fixture.
- The maximum remote distance using the 16AWG wire is 250ft. Contact the factory for more information.
- The AC power is fed to the EMG-1AC Series.
- The AC driver receives power from the EMG-1AC Series. Identify the output wires of the EMG-1AC Series by the presence of the purple and blue leads.

STEP 1: DISCONNECT AC POWER FROM FIXTURE

- Disconnect all power sources from lighting fixture and ensure they remain off during installation or maintenance.
- Disconnect power leads from the AC driver.
- Select a suitable location for the EMG-1AC Series and install so that it's output leads can connect to the input leads of the AC driver.
- See **FIG 1** for typical installation and select appropriate mounting.

STEP 2: WIRING THE EMG-1AC SERIES

- Use the wiring diagram found as reference.
- Connect the AC power source leads to the input of the EMG-1AC.
- Connect the output leads of the EMG-1AC Series to the AC driver.
- Wire the AC driver with the lamp in accordance with manufactures installation instructions.
- Make sure all connections are in accordance with the National Electrical Code and/or any local regulations.
- In a readily visible location attach the CAUTION LABEL.

STEP 3: MOUNTING THE TEST ACCESSORIES

- Gray wire and red wire of emergency backup into the switch box.
- Connect the gray and red wire of the indicator light. Attach the panel switch to switch box.
- The indicator light and test switch should mount into fixture.

STEP 4: JOIN THE EMG-1AC SERIES CONNECTOR & APPLY POWER

- After installation is complete, join the EMG-1AC Series connector and turn on AC power.
- At this point power should be connected to both the AC driver and the EMG-1AC Series and the charging indicator light should illuminate indicating the battery is charging.
- A short-term discharge test may be conducted after the EMG-1AC Series has been charging for 1 hour. Charge for 24 hours before conducting a long-term discharge test. Refer to operation.

OPERATION

During normal operation AC power is supplied to the AC driver through the EMG-1AC Series and charges the battery. The EMG-1AC Series works with AC input line voltage (100-277 VAC) and automatically sets the output voltage during emergency mode.

When AC power fails, the EMG-1AC Series automatically switches to emergency mode keeping the load illuminated for a minimum of 90 minutes. When AC power is restored, the EMG-1AC returns to charging mode. The EMG-1AC series consists of a low-battery voltage disconnect which is reset when AC power is restored.

MAINTENANCE

Although no routine maintenance is required to keep the EMG-1AC Series functional, it should be checked periodically to ensure that it is working.

1. Visually inspect the charging indicator light to ensure it's illuminated.
2. Test the emergency operation of the fixture at 30-day intervals for a minimum of 30 seconds. The lamp should operate at full illumination.
3. Conduct a 90-minute discharge test once a year. The lamp should operate at full illumination for at least 90 minutes.
4. If red indicator flashes or dies that indicates the emergency power supply is abnormal.

GENERAL WIRING DIAGRAM

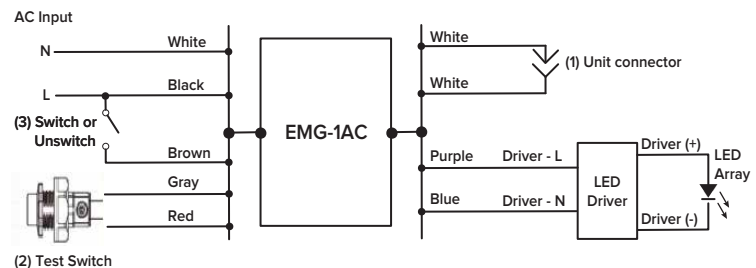

NOTE: Make sure the necessary branch circuit wiring is available. An unswitched source of power is required.

ALTERNATIVE WIRING DIAGRAMS

Installing the EMG-1AC with a Line Voltage tube - single end

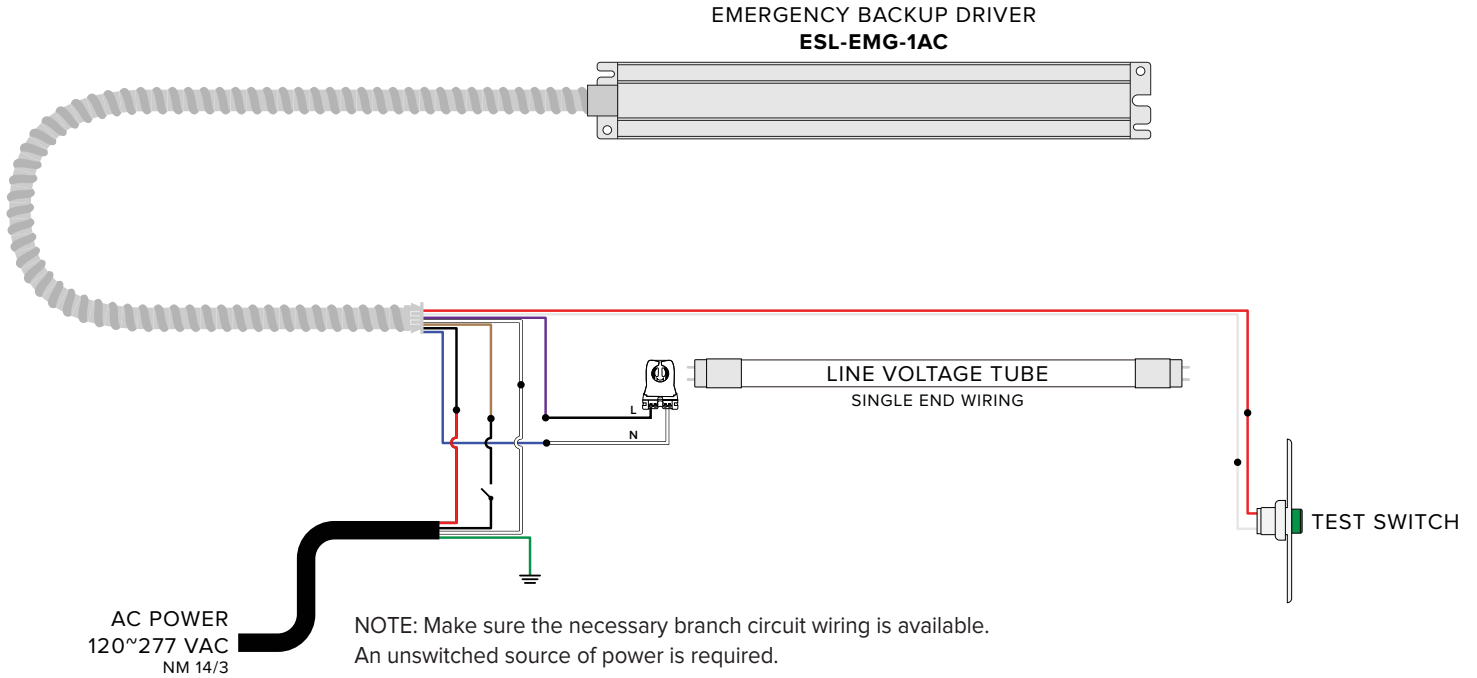

Installing the EMG-1AC with a Line Voltage tube - dual end

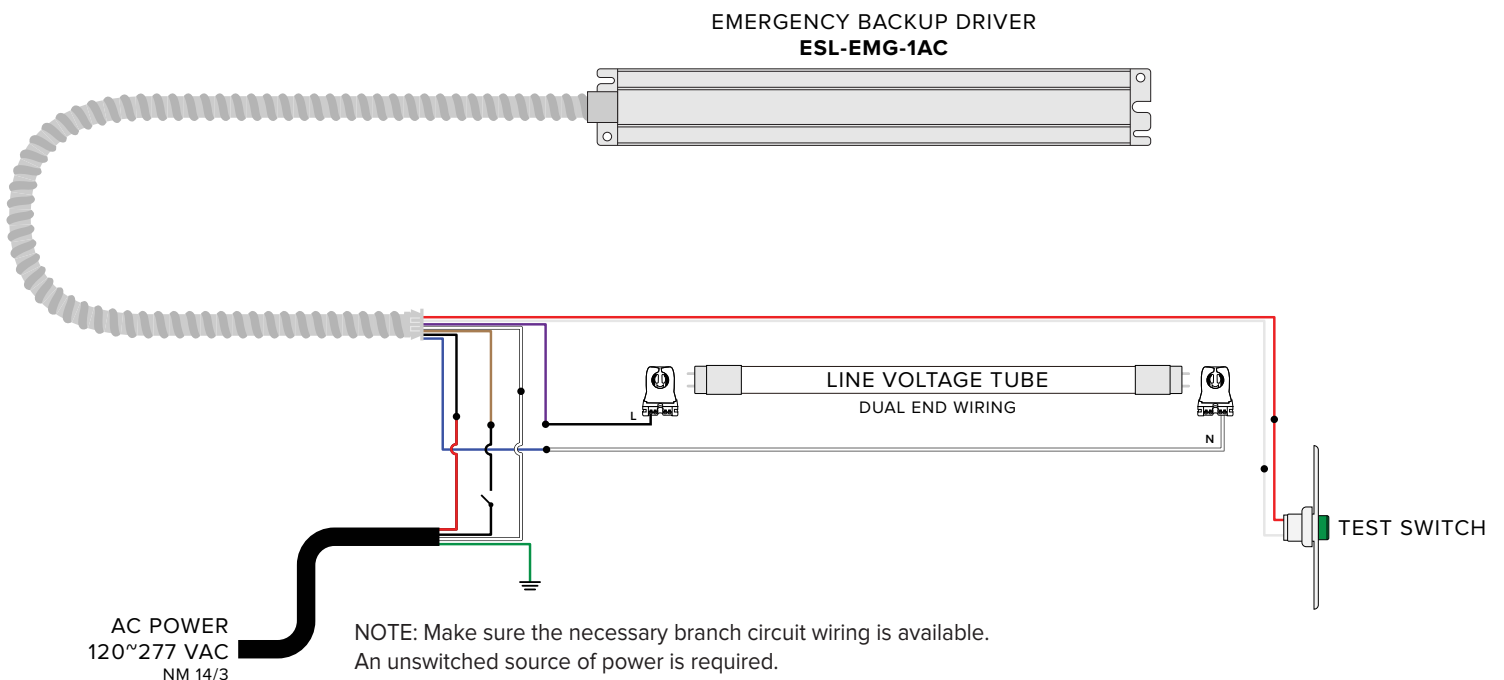

ALTERNATIVE WIRING DIAGRAMS

Installing the EMG-1AC with a Recessed Downlight

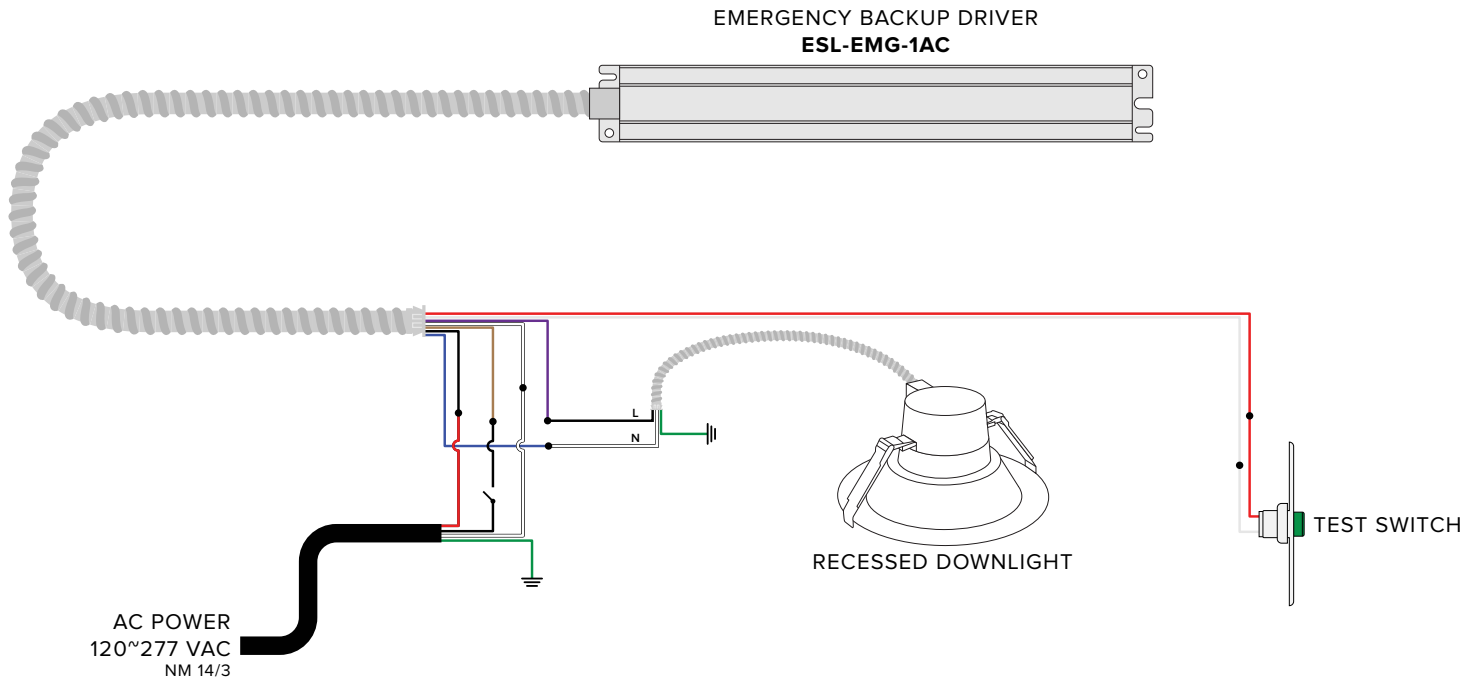

Installing the EMG-1AC without a switched line

