

IMPORTANT SAFEGUARDS

WHEN USING ELECTRICAL EQUIPMENT, BASIC SAFETY PRECAUTIONS SHOULD ALWAYS BE FOLLOWED.

READ AND FOLLOW ALL SAFETY INSTRUCTIONS

1.

To prevent electrical shock, switch off the main power supply until installation is complete and AC power is supplied to this product.

2.

This product requires an unswitched AC power supply of 120-277 VAC, 50/60Hz.

3.

Make sure all connections are in accordance with the National or Canadian Electrical Code as well as any local regulations.

4.

To reduce the risk of electrical shock, disconnect both normal and emergency power supplies and connector of this product before servicing.

5.

This product is for use with an emergency LED lighting load with a maximum rated voltage of 60 VDC, and a maximum rated current of 1A. It can provide a minimum of 90 minutes of illumination when under the emergency mode.

6.

The ESL-EMG-2DC are UL Component Recognized for factory installation.

7.

This product is suitable for use in dry or damp locations. Do not mount it near gas heaters, air outlets or other hazardous locations.

8.

Use this product in 32°F (minimum) to 122°F (maximum) ambient temperatures.

9.

The use of accessory equipment not recommended by the manufacturer may cause an unsafe condition and void the warranty.

10.

Do not use this product for anything other than its intended use.

11.

Installation and service should be performed by qualified service personnel.

12.

This product should be mounted in locations and at heights where it will not easily be subjected to tampering by unauthorized personnel.



This product contains a rechargeable nickel-metal hydride battery. THE BATTERY MUST BE RECYCLED OR DISPOSED OF PROPERLY TO PREVENT FIRE.



CAUTION: Before installing make certain the AC power is off and the LED lamp emergency backup unit connector is disconnected.

1. Specification of ESL-EMG-2DC Series

See the ESL-EMG-2DC SERIES SPECIFICATION chart below for the model selected.

MODEL	VOLTAGE OUTPUT	EMERGENCY OUTPUT (CONSTANT)
ESL-EMG-2DC-5W	13-60 VDC	5 WATTS
ESL-EMG-2DC-9W	14-60 VDC	9 WATTS
ESL-EMG-2DC-15W	15-60 VDC	15 WATTS
ESL-EMG-2DC-25W	25-60 VDC	25 WATTS

2. Installing the ESL-EMG-2DC

The ESL-EMG-2DC should be mounted inside the luminaire and is a factory install only.

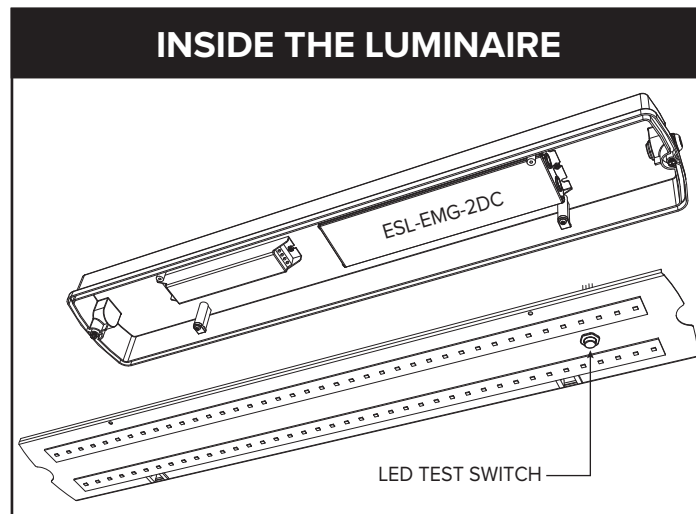

3. Installing the LED Test Switch

Select a convenient location for the LED Test Switch so that it can be seen after installation. Drill a 1/2" hole for mounting. Connect the wires from the LED Test Switch to the ESL-EMG-2DC model according to the wiring diagram on page 3.

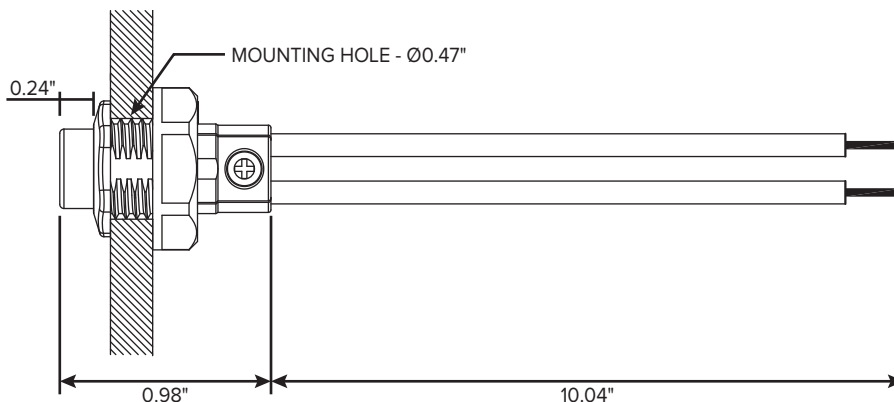

1.

The ESL-EMG-2DC requires an unswitched AC power supply of 120-277 VAC, 50/60Hz.

2.

The ESL-EMG-2DC and AC driver must be on the same branch circuit. Ensure the output current of the AC driver does not exceed 5A.

3.

Refer to the wiring diagram below or contact factory for additional information or help.

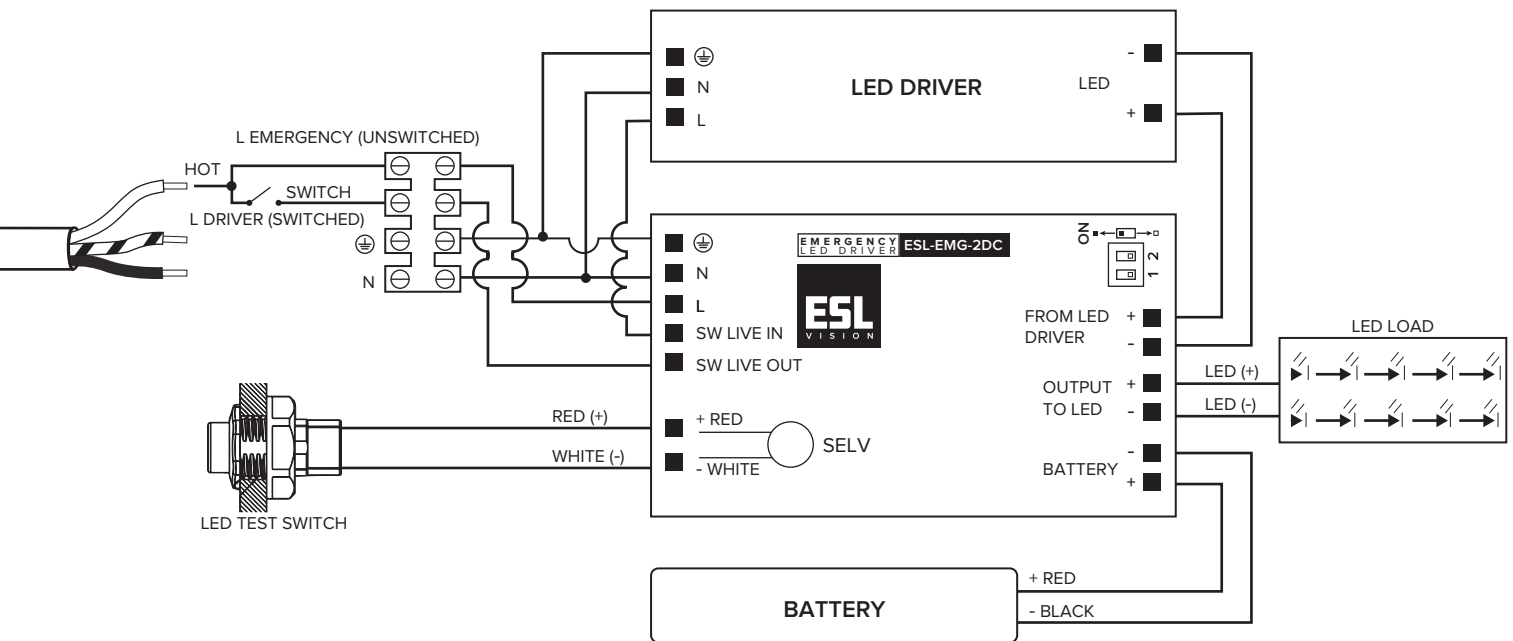

Wiring Configuration

ESL-EMG-2DC

Terminal block with external battery pack, choosing the different combination of the DIP switches and the corresponding battery pack to have different ESL-EMG-2DC models with different emergency power outputs.

1	2	MODEL	POWER	BATTERY
OFF	OFF	ESL-EMG-2DC-5W	5W	9.6V, 1.5AH
ON	OFF	ESL-EMG-2DC-9W	9W	10.8V, 2.1AH
OFF	ON	ESL-EMG-2DC-15W	15W	10.8V, 3.8AH
ON	ON	ESL-EMG-2DC-25W	25W	14.4V, 4.5AH

BATTERY MOUNTING BOX (OPTIONAL)*
*Contact factory for information

Operation

When AC power is applied, the LED test switch will be illuminated, indicating that the batteries are being charged. When AC power fails, the ESL-EMG-2DC automatically switches to emergency power, operating the LED loads at the rated power. The LED test switch will switch off. When the AC power is restored the emergency module switches the system back to normal operation and resumes charging the battery. The minimum emergency operation time is 90 minutes. The charging time for the full discharged battery is 24 hours.

Testing and Maintenance

Performing periodical tests are recommended to ensure the system is working properly.

1.

Visually inspect the LED test switch monthly. IT should be illuminated when AC power is present.

2.

Conduct a 30 second discharge test by switching off the main power every month. The LED test switch should switch off and LED loads should operate at reduced illumination.

3.

Conduct a 90 minute discharge test once a year. The LED loads should operate at reduced illumination for at least 90 minutes.

Auto Test

The ESL-EMG-2DC Series has an auto test function which saves the cost of manual maintenance.

1.

Instant Auto Test: When the system is connected properly and powered on the ESL-EMG-2DC model will auto test if the load and battery pack is connected properly and the battery is charging as normal. If there is any abnormalities, the LED test will flicker. The the abnormality is resolved, the test switch will stay lit with no flicker.

2.

Preprogrammed scheduled Auto Test: (A) Carry out first monthly auto test after initial power on for at least a full 24 hours or more. Afterwards carryout a monthly auto test every 30 days. (B) Carry out a annual auto test every 52 weeks after first power on. (C) Auto test timing. To reduce the conflict that auto test is executing when the lighting is in use, the preprogrammed scheduled auto test will be executed 2 hours later than the normal operation is disconnected (switched off). For applications where lighting remains illuminated, the module will postpone the scheduled test accordingly, but will not postpone later than the preprogrammed scheduled latest test time. (D) Monthly auto test. The Monthly auto test should be executed every 30 days and should test for; the switchover of normal and emergency modes; if the emergency functions and that the battery charging and discharge condition is normal. Auto test time is approximately 30 seconds. (E) Annual auto test. The annual auto test should be executed every 52 weeks after a full 24 hour charge of the battery. This will test; if the battery voltage is equal to or higher than the limit after a full 24 hour charge; if the emergency operation time is over 90 minutes; if the battery voltage after 90 minutes of emergency operation is equal to or higher than 87.5% of the initial voltage.

- During the auto test, in case a power failure happens and the power cannot be on until the auto test completes, the auto test will be performed again after AC power has been on for 24 hours.

- If the emergency mode makes the battery discharge completely under the power off condition, the preprogrammed scheduled auto test will resume as soon as AC power is restored.

Manual Test

(1) Press the LED test switch one time to put into emergency mode. (2) Press the LED test switch two times within 5 seconds to put into monthly test sequence. After test is finished the next monthly test will count from this date. (3) Press the LED test switch three times within 5 seconds to put into annual test. After test is finished the next annual test will count from this date. (4) During the manual test, press the LED test switch above 3 seconds, then the manual test can be terminated (the preprogrammed scheduled auto test time will not change).

LED Test Switch Indications

- LED test switch on: Normal

- LED test switch gradual change: In testing mode

- LED test switch off: Power failure

- LED test switch flickering: Abnormal issue