

Key Features & Benefits:

- Fully Adjustable High and Low Dimmed Light Levels
- Provides Line Voltage On/Off Switching
- 0-10V Dimming Control
- Works With Ballast or LED Drivers
- Adjustable Via Remote Control
- Adjustable Time Delay and Cut Off Delay
- Optional Cut Off Delay
- Time Delay From 5 to 30 Minutes
- Adjustable Ramp Up and Fade Down Times

Project: _____

Date: _____

Catalog #: _____

Notes: _____



Technical Specifications:

Power Supply: 120-277 VAC

Maximum Load:

Resistive/Tungsten - 600W@120V

Ballast Electronic (LED) - 800/1200VA@120-277V

HF System: 5.8Ghz CW

Dimming Control Output: 0-10V Max. 25mA sinking current

Detection Radius/angle: Max meters/360°

Mounting Height: 20ft Max

Remote Range: 33ft (10m) indoor, no backlight

Humidity: Max 95% RH

Temperature: -104°F ~ 158°F (-40°C ~ 70°C)

ESL-REM-101*

*ESL-REM-101 Sold Separately



Catalog Data:

ITEM#	COLOR	DESCRIPTION
ESL-40CC	WHITE	360° lens, maximum coverage of 48' in diameter. From 8' to 20' in height
ESL-REM-101	BLACK	Remote control for 20CC, 40CC and 50CC



Dimensions:

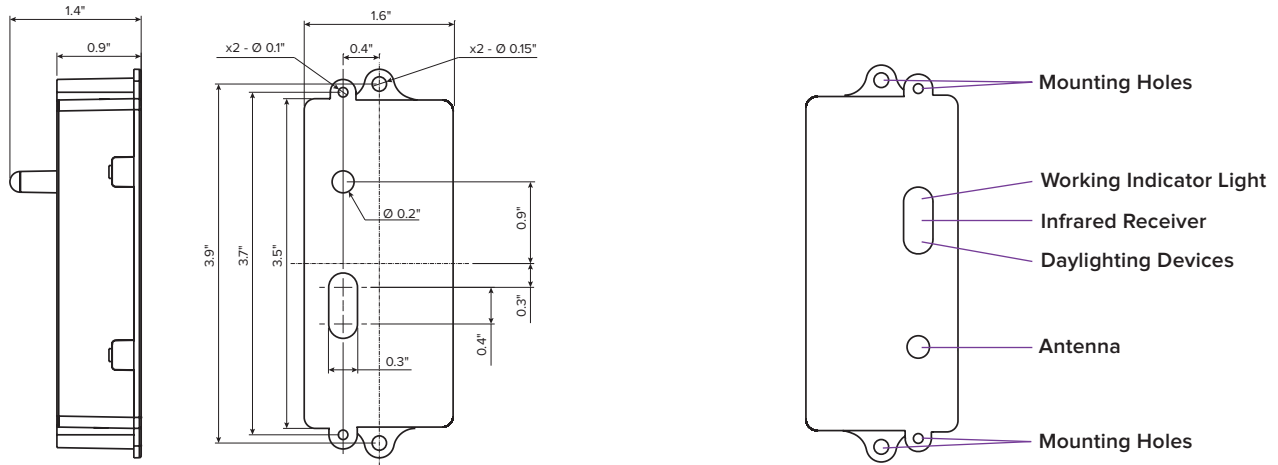

Coverage:

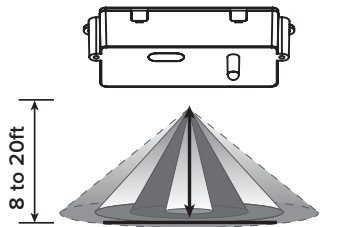

Height of Installation - 8 to 20ft

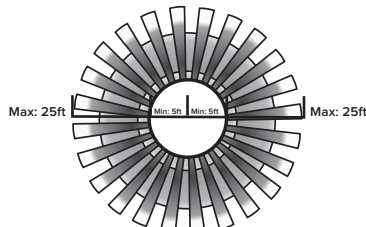

(Height of Installation - 8ft)
Detection Range

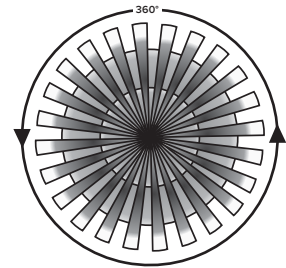

Detection Angle

Wiring:

400C wiring with dimming ballast or LED driver

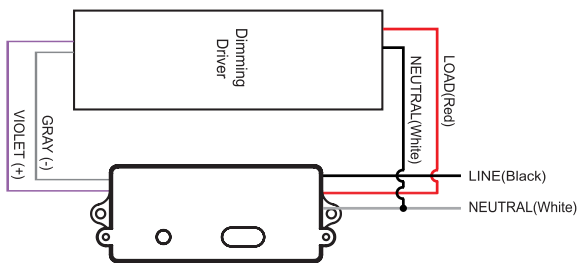

400C wiring with non-dimming ballast or LED driver

