

Key Features & Benefits:

- DLC Listed 2x2 Troffer Retrofit Kit
- Installs in Minutes
 - Magnetic Clips
 - Hex Tek Screws
- 24 Available 2x2 Retrofit Kits
 - 36 Available 1x4 Retrofit Kits
 - 54 Available 2x4 Retrofit Kits
- 1,829 to 5,332 Troffer Kit Lumens
- 2,360 to 6,552 Linear Ambient Kit Lumens
- Long Life 80,000 Hours (L70)
 - 10 year warranty (12 hour run times)
 - 7 year warranty (24 hour run times)



Project: _____ Date: _____

Catalog #: _____

Notes: _____

Technical Data:

Light Specifications:

- Linear Ambient Kit Lumens: Up to 4,797 Lumens
- Linear Ambient Kit Efficacy (lm/W): Up to 123 Lumens per Watt
- Troffer Kit Lumens: Up to 3,843 Lumens
- Troffer Kit Efficacy (lm/W): Up to 105 Lumens per Watt
- Kelvin: 3000K, 3500K, 4000K, 5000K
- Color Rendering Index (CRI): >82
- Rated Life: > 80,000 hrs

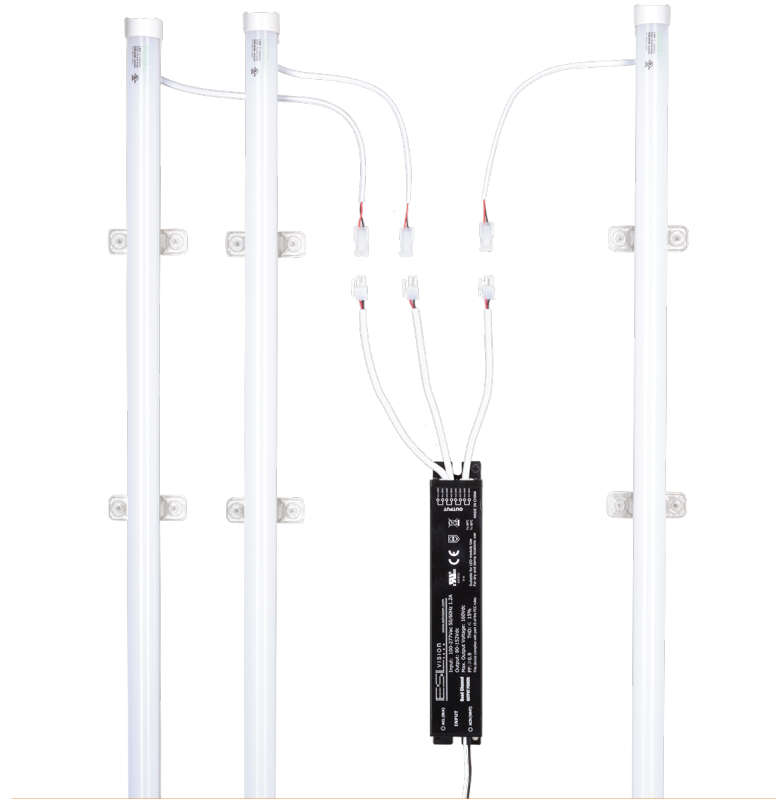

Driver Data:

- Input Voltage: 120-277 VAC
- Driver Output: Triple Output
- Output Power: 39 Watts
- Input Current @ 120V: 0.325 Amps
- Input Current @ 240V: 0.1625 Amps
- Input Current @ 277V: 0.141 Amps
- Total Harmonic Distortion (THD): <10%
- Operating Temperature: -4 ~ 122°F



Catalog Data:

ITEM#	WATTS	KELVIN	TROFFER KIT LUMENS	TROFFER KIT EFFICACY (lm/W)	LINEAR AMBIENT KIT LUMENS	LINEAR AMBIENT KIT EFFICACY (lm/W)	DLC QPL CODE
ESL-Ti-K22-S-39W-3L-F30	39W	3000K	3,751	103	4,680	120	PJ9RD34N
ESL-Ti-K22-S-39W-3L-F35	39W	3500K	3,755	103	4,680	120	PUV5GAH3
ESL-Ti-K22-S-39W-3L-F40	39W	4000K	3,797	104	4,719	121	PR3SCD3F
ESL-Ti-K22-S-39W-3L-F50	39W	5000K	3,843	105	4,797	123	PAVECUWW

Ordering Guide:

ESL	Ti	K22	S	39W	3L	F		
ESL	TYPE	SERIES	CLASS	WATTS	Ti	LENS	KELVIN	OPTIONS
	Ti Series	K22 (2x2 Kit)	S	30W (30 Watts) 39W (39 Watts)	3L (Three Ti)	F (Frosted)	30 (3000 Kelvin) 35 (3500 Kelvin) 40 (4000 Kelvin) 50 (5000 Kelvin)	

Alternate 2'x2' Ti Kit Options:

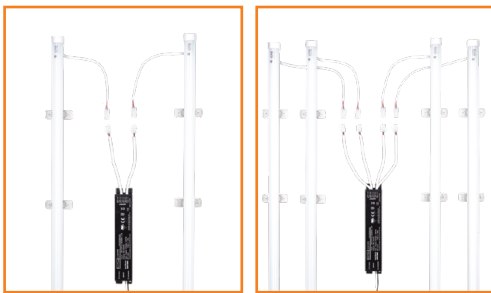

2L Output

4L Output

What's Included:

- (3) LED Ti Bars
- (1) LED Driver
- (6) Ti Clips with Rare Earth Magnets
- (12) Self Tapping Screws
- (1) UL1598C Certification Label

Options (Add as Suffix):

- ESL-EMG-4DC-9W (Emergency Back Up, DC, 9 Watt)

Dimensions:

Ti:

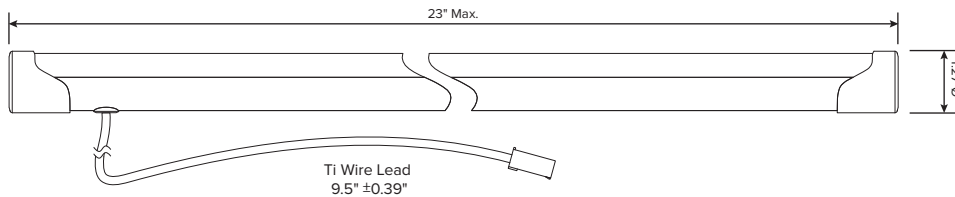

Clip:

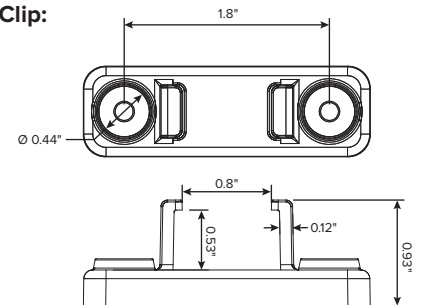

Driver:

