



LED LOW BAY SERIES



TiHO - LB2 - 60 Watts

PAGE 1 OF 2

Key Features & Benefits:

Intended Use

The ESL TiLB series is the perfect LED replacement fixture for HID and fluorescent high bay systems in retail and industrial spaces. Featuring over 140 lumens per watt, exceptional color rendering, ultra-long life and instant on/off illumination.

Construction

Housing is made from 22 gauge pre-painted steel. Air vents surround the driver and Ti's in the back of the fixture to maximize performance, reliability and life. Access plate in the back makes wiring fast and hassle-free. Back of fixture is designed with built-in mounting holes for tong hanger, cable kit and surface mount. Multiple KO's make for extremely easy installation.

Adder Options

Multiple adder options are available including: Emergency Backup, Lens Options, Wire Guards, Mounting Options, Photocell and Occupancy Sensors, Cords and Flexible Conduit. Please contact factory for Low Bay Adder sheet.

Project: _____

Date: _____

Catalog #: _____

Notes: _____



Electrical Data:

Light Specifications:

- Lumen Output: Up to 8,226 Lumens
- Efficacy (lm/W): Up to 135 Lumens per Watt
- Kelvin: 4000K, 5000K
- Color Rendering Index (CRI): >82
- Rated Life: > 80,000 hrs

Driver Data:

- Input Voltage: 120-277 VAC
- Input Power: 60W
- Input Current @ 120V: 0.5 Amps
- Input Current @ 240V: 0.25 Amps
- Input Current @ 277V: 0.216 Amps
- Total Harmonic Distortion (THD): <10%
- Power Factor: >0.99
- Operating Temperature: -4 ~ 122°F

Catalog Data:

ITEM#	WATTS	LUMEN OUTPUT	EFFICACY (lm/W)	KELVIN
ESL-TiHO-LB2-S-60W-F40	60W	7,192	118	4000K
ESL-TiHO-LB2-S-60W-F50	60W	7,336	119	5000K
ESL-TiHO-LB2-P-60W-F40	60W	8,074	133	4000K
ESL-TiHO-LB2-P-60W-F50	60W	8,226	135	5000K

*Made in the USA option available upon request

Ordering Guide:

ESL	-	TiHO	-	LB2	-	ESL	-	60W	-	F	-	
ESL		TYPE		SERIES		LISTING		WATTS		LENS		KELVIN
		TiHO Series		LB2 (Low Bay 2)		S P		60W (60 Watts)		F (Frosted)		40 (4000 Kelvin) 50 (5000 Kelvin)
												OPTIONS

Example Part Number: **ESL-TiHO-LB2-P-60W-F40**

Dimensions:

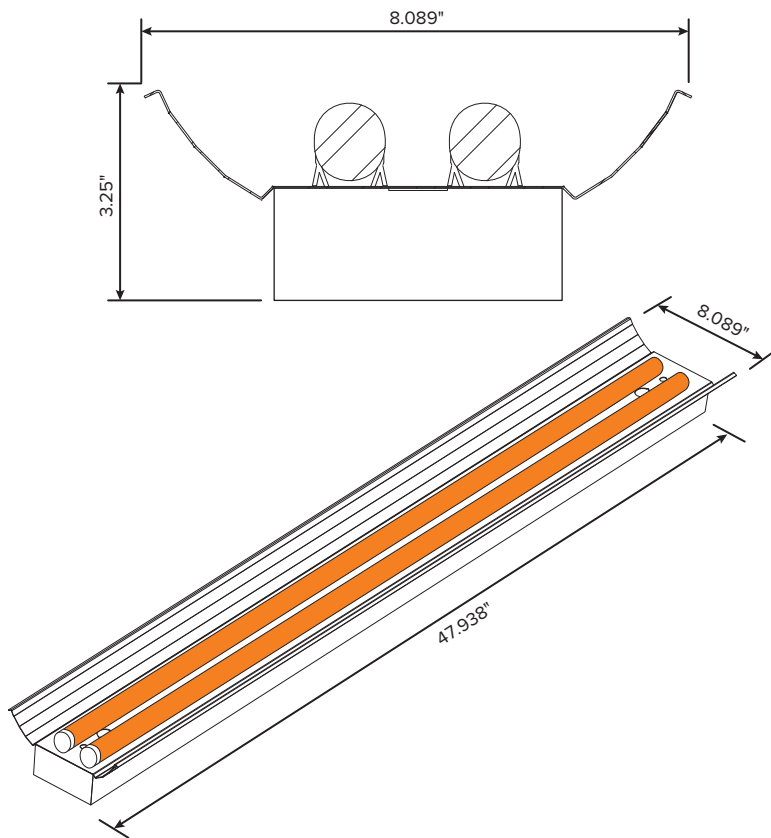

Options (Add as Suffix):

- **Emergency:**
 - ESL-EMG-2DC-9W (Internal emergency backup)
- **Sensors:**
 - ESL-1OCC-HDO (External Occupancy Sensor)
- **Cord Sets:***
 - ESL-CS3W-6 (Cord Set, White, 3 wire, 6 foot)
 - ESL-CS3W-6P (Cord Set, White, 3 wire, 6 foot, Standard Plug)
 - ESL-CS3W-6TL (Cord Set, White, 3 wire, 6 foot, Twist lock Plug)
 - ESL-CS3W-12 (Cord Set, White, 3 wire, 12 foot)
 - ESL-CS3W-12P (Cord Set, White, 3 wire, 12 foot, Standard Plug)
 - ESL-CS3W-12TL (Cord Set, White, 3 wire, 12 foot, Twist lock Plug)
- **Whips: Flexible Conduit:**
 - ESL-WP3-6 (Whip, 3 wire, 6 foot)
 - ESL-WP3-12 (Whip, 3 wire, 12 foot)
- **Mounting:**
 - ESL-VH01 (V-Hangers sets)
 - ESL-JC01 (Jack Chain - per foot)
 - ESL-HB-PM01 (Pendant Mounting)
- **Miscellaneous:**
 - ESL-SPD-277-1 (Surge Protector; 100-277V)
 - ESL-480V-SD01 (480 Volt Step Down Transformer)

*Other lengths and black cord available upon request

System Performance Table:

6,000 TO 10,000 LUMENS

ESL VISION TI COMPARISONS	FIXTURE TYPE	FIXTURE LUMENS	FIXTURE WATTAGE	LUMENS PER WATT	*ANNUAL RUN TIME COST	LIFETIME	WARRANTY
STANDARD TI SERIES	ESL-TiHO-LB2-S-60W-F50	7800	60	130	\$59.13	80,000 hrs	10 year
PREMIUM TI SERIES	ESL-TiHO-LB2-P-60W-F50	8580	60	143	\$59.13	80,000 hrs	10 year
COMPARISON SYSTEM	T8 32 WATT 2 LAMP	6189	74	84	\$72.93	24,000 hrs	3 year
	T5HO 54 WATT 2 LAMP	8742	122	72	\$120.23	24,000 hrs	3 year