

WARNING

Risk of electric shock. Disconnect main power at circuit breaker before installing or servicing the fixture

1. Do not make or alter any open holes in an enclosure of wiring or electrical components during kit installation.
2. To prevent wiring damage or abrasion. Do not expose wiring to edges of sheet metal or other sharp objects.
3. High Voltage. This device must be installed by a qualified installer or electrician. Follow all applicable electrical codes for installation.

INSTRUCTIONS

1. Turn off power circuit breaker or test that power is off before wiring.

NOTE: Use a non-metal electrical enclosure for best wireless communication performance

2. Follow the below wiring diagram for installation

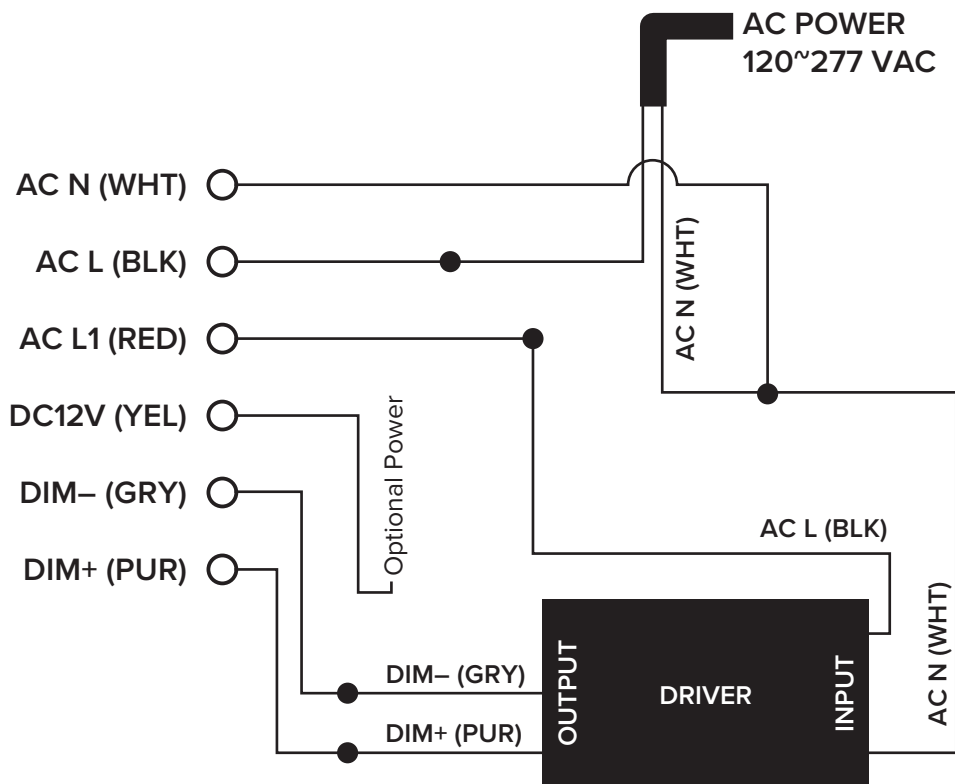

3. Connect wires with wire nuts and cap any unused wires.
4. Restore power to the circuit.
5. Use the ESL Vision APP to learn in the device.