

Illumination:

- Ultra bright, energy efficient, long life Red or Green LEDs.
- UV-stabilized ultra-clear acrylic edgelit panel provides consistent, uniform illumination.
- Double face utilizes factory installed silver or white mylar background panel.

Electrical:

- Dual 120/277 voltage standard.
- Charge rate power “ON” LED indicator light and push-to-test switch for mandated code compliance testing.
- 4.8V long life, maintenance-free, rechargeable NiCd battery (EM models only).
- Internal solid-state transfer switch automatically connects the internal battery to LED board for minimum 90-minute emergency illumination.
- Fully automatic solid-state, two rate charger initiates battery charging to recharge a discharged battery in 24 hours.

Mounting:

- Aluminum mounting canopy included for top, end or back mount.

Housing:

- Premium-grade, extruded aluminum housing (also available in optional black or white powder-coated finishes).
- Self-adhesive Chevron appliques and guide template provided for directional indication.

Options:

- 2C-120V/2C-277V: Voltage-specific dual circuit option on the AC-only unit enables it to be connected to two different supplies at the same time.
- SDT: Self-diagnostic feature performs monthly, biannual, and annual tests to ensure reliable operation and meets electrical and life safety codes.
- USA: Substantial transformation assembly in the U.S. complies with “Assembled in the USA” under the Buy American Act.



Project: _____ Date: _____
 Catalog #: _____
 Notes: _____



warranty / Listing:

Five year warranty on all electronics and housing. Battery prorated for five years.
 Meets UL924, NFPA 101 Life Safety Code, NEC, OSHA, Local and State Codes.
 UL Listed for damp locations (0°C – 50°C).
 Certified to CEC under Title 20 Regulations.

Dimensions:

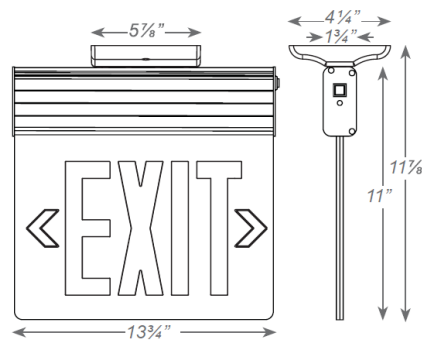

Catalog Data:

Sample Part Number: ELXTEUIRCAEM

MODEL	No. of FACES	LETTER COLOR	PANEL	HOUSING COLOR	BATTERY	OPTIONS
ELXTEU	1 Single Face	R Red	C Clear ¹	W White	(blank)	2C-120 Dual Circuit With 120V Input ²
	2 Double Face	G Green	M Mirror	B Black	EM	2C-277 Dual Circuit With 277V Input ²
			W White	A Aluminum		SDT Self-Diagnostics ³
						USA Assembled In USA
						SPV 208/220/240 Volt, 50/60Hz ⁴
						CUSTOM Custom Wording

¹ With single face only.
² Available only with AC units.
³ Available only with EM units.
⁴ Not available with SDT.