

⚠ WARNING

1. To avoid electric shock, disconnect power at source prior to installation.
2. The installation should be performed by qualified electricians or lighting technicians.
3. Before conducting any installation, maintenance, or removal, disable all power.
4. Do not touch the fixture while it is in service.
5. If there is any problem with the fixture, turn off power and DO NOT attempt repair unless you are a qualified technician or the customer service member.

Recessed Installation



1 Remove the ceiling panel where the fixture is to be installed. Raise the fixture above the bar,

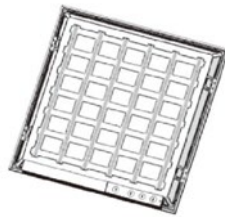

2 Ensure that the power is turned off at the breaker. Connect power to the driver as show in **Wiring Diagram 1**.

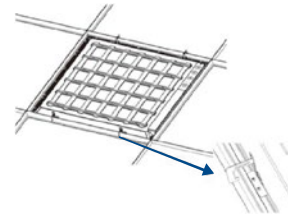

3 Fold the four (4) protection brackets up so they are positioned above the T-bar.

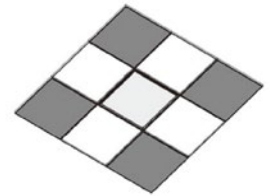

4 Gently rest the fixture onto the T-bar and ensure that it fits properly.

Surface Mount Installation

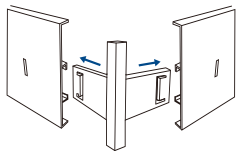

1 Assemble three sides of the frame using the snap-in plastic corners.

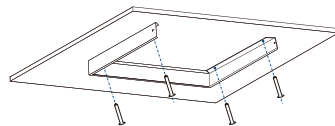

2 Attach the frame to the ceiling with screws. Remove side B2 of the frame.

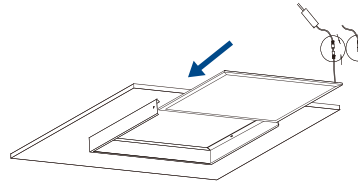

3 Partially slide the fixture into the frame. Ensure that the power is turned off at the breaker. Connect power to the driver as show in **Wiring Diagram 1**.

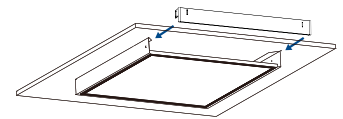

4 Slide the fixture the rest of the way into the frame. Reattach side B2 to secure the fixture inside the frame.

Suspended Installation

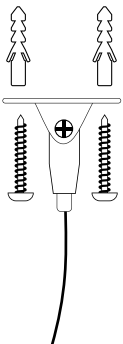

1 Using anchors appropriate for the surface, attach the cable to the ceiling. Hook the lobster claw on the other end of the cable to the fixture.

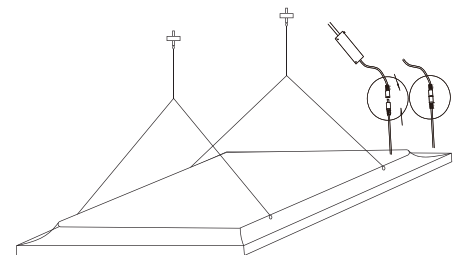
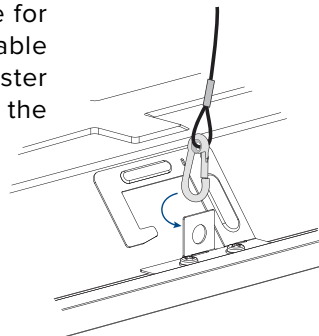

2 Ensure that the power is turned off at the breaker. Connect power to the driver as show in **Wiring Diagram 1**.

Emergency Battery Installation

1 Insert the high-voltage side (**Flex A**) of the emergency power into the bracket slot. Then fix the emergency battery to the supporting bridge by using two screws on **Flex B** side and two screws on **Flex A** Side.

2 Install the EM supporting bridge on the back plate and screw in A1/A2/B1/B2 and wiring.

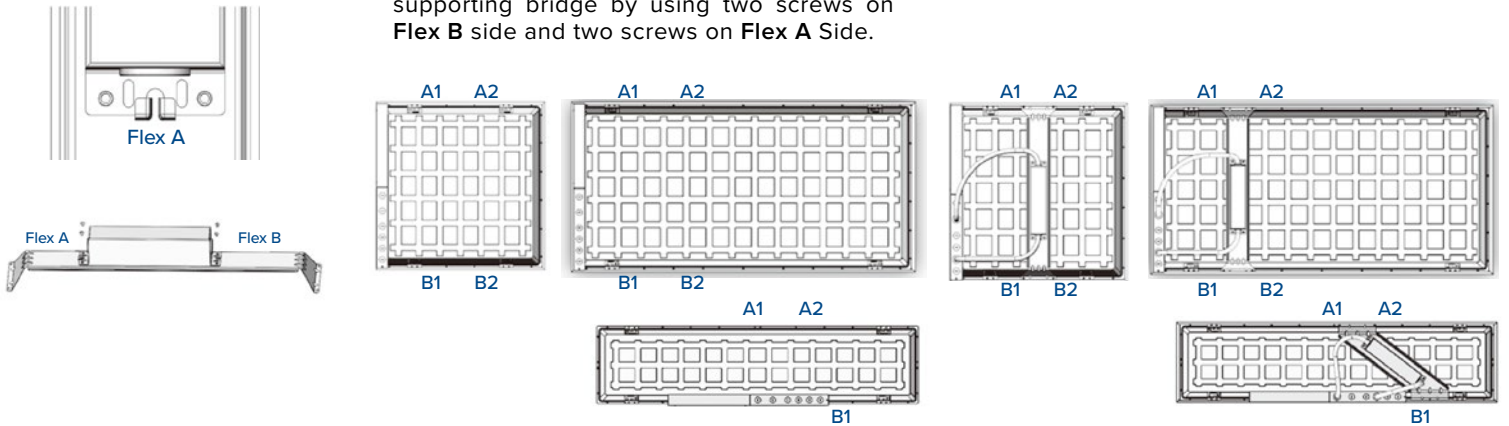

Wiring Diagram 1

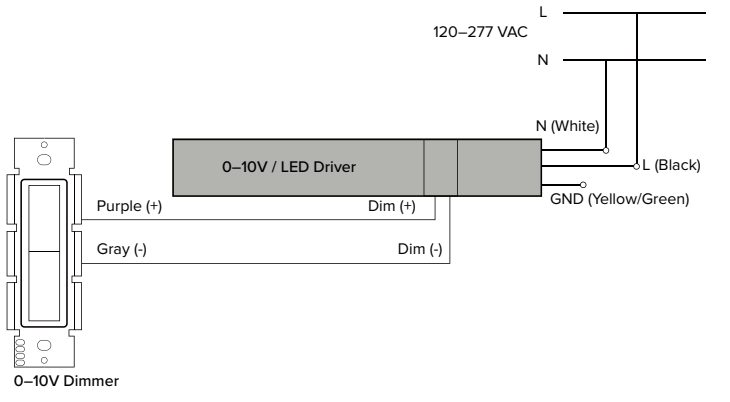

EMG Wiring Diagram

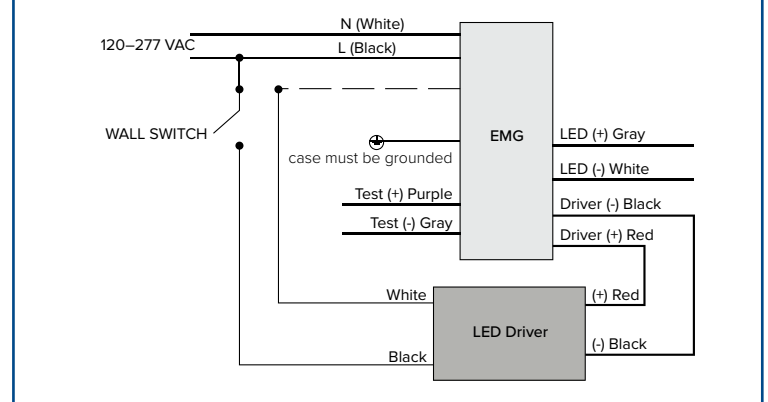

LED Driver

EM

