

Project: _____ Date: _____

Catalog #: _____

Notes: _____

Illumination:

- Sealed and gasketed weather proof lamp heads with high performance chrome-plated metallized reflector and tempered glass lenses for optimal light distribution.
- Long lasting efficient ultra bright white LED lamp heads.
- 1.875 watt (15 LEDs x 0.125) per head.

Electrical:

- Dual 120/277 voltage.
- Charge rate/power "ON" LED indicator light and push-to-test switch for mandated code compliance testing.
- 9.6V long life, maintenance-free, rechargeable NiCd battery.
- Remote capacity of 3.7 watt standard in operating temperatures of 0°C – 50°C.
- Internal solid-state transfer switch automatically connects the internal battery to LED lamp heads for minimum 90-minute emergency illumination.
- Fully automatic solid-state, two rate charger initiates battery charging to recharge a discharged battery in 24 hours.

Mounting:

- External mounting brackets for simplified surface mounting.
- Knockout for conduit applications.

Housing:

- Corrosion-resistant 5VA flame retardant UV-stabilized polycarbonate in gray or black finish.
- Sealed and gasketed housing with hinged cover.
- Sealed test switch.

Options:

- CEC: Certified to CEC under Title 20 Regulations.



Warranty / Listing:

Five year warranty on all electronics and housing. Battery prorated for five years.
 Meets UL924, NFPA 101 Life Safety Code, NEC, OSHA, Local and State Codes.
 UL Listed for wet locations (-20°C – -50°C).

Dimensions:

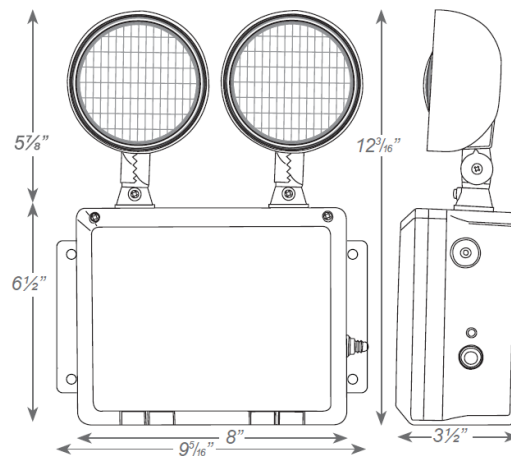

Catalog Data:

Sample Part Number: LEDTFX-2

Special voltage options available.
 Check with your Best Lighting Representative.

MODEL	HOUSING COLOR	OPTIONS
LEDTFX-2	(blank) Gray B Black	CEC Title 20 Compliant