

Illumination:

- Ultra bright, energy efficient, long life Red or Green LEDs.
- UV-stabilized ultra-clear acrylic edgelit panel provides consistent, uniform illumination.
- Double face utilizes factory installed silver or white mylar background panel.

Electrical:

- Dual 120/277 voltage standard.
- Unique bi-color LED indicator light alerts occupant on battery condition (Green-normal, Red-check battery).
- Push-to-test switch for mandated code compliance testing.
- 4.8V long life maintenance-free, rechargeable NiCd battery (EM models only).
- Internal solid-state transfer switch automatically connects the internal battery to LED board for minimum 90-minute emergency illumination.
- Fully automatic solid-state, two rate charger initiates battery charging to recharge a discharged battery in 24 hours.

Mounting:

- EZ-snap mounting canopy included for top, end or back mount.

Housing:

- Injection-molded, engineering grade 5VA, flame retardant, high-impact resistant thermoplastic housing in silver, white, or black finish.
- Self-adhesive Chevron appliques and guide template provided for directional indication.

Options:

- Custom: Signs available with requested 'special' wording.
- SDT: Self-diagnostic feature performs monthly, biannual, and annual tests to ensure reliable operation and meets electrical and life safety codes.
- 2C: Dual circuit option on the AC-only unit enables it to be connected to two different (one acting as a back-up to the other) supplies at the same time.
- SPV: UL Listed for 208/220/240 Volt, 50/60Hz.

Project: _____

Date: _____

Catalog #: _____

Notes: _____



Warranty / Listing:

Five year warranty on all electronics and housing. Battery is prorated for five years.

Meets UL924, NFPA 101 Life Safety Code, NEC, OSHA, Local and State Codes.

UL Listed for damp locations (0°C – 50°C).

Certified to CEC under Title 20 Regulations.

Dimensions:

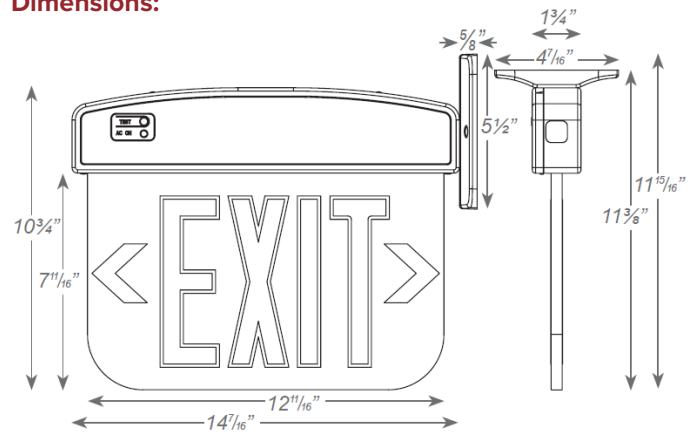

Catalog Data:

Sample Part Number: PLELRXTEU1RCAEM

MODEL	No. of FACES	LETTER COLOR	PANEL	HOUSING COLOR	BATTERY	OPTIONS
PLELRXTEU	1	Single Face	R Red	C Clear ¹	W White	(blank) CUSTOM Custom Wording
	2	Double Face	G Green	M Mirror	B Black	EM Battery Self-Diagnostics ²
				W White	A Silver	Backup 2C Dual Circuit Operation ³
						SPV 208/220/240 Volt, 50/60Hz ⁴

¹ With single face only.

² Available only with EM units.

³ Available only with AC units.

⁴ Not available with SDT.