

Illumination:

- Ultra bright, energy efficient, long life Red or Green LEDs.
- UV-stabilized ultra-clear acrylic edgelit panel provides consistent, uniform illumination.
- Double face utilizes factory installed silver or white mylar background panel.

Electrical:

- Dual 120/277 voltage standard.
- Charge rate/power “ON” LED indicator light and push-to-test switch for mandated code compliance testing.
- 4.8V long life, maintenance-free, rechargeable NiCd battery (EM models only).
- Internal solid-state transfer switch automatically connects the internal battery to LED board for minimum 90-minute emergency illumination.
- Fully automatic solid-state, two rate charger initiates battery charging to recharge a discharged battery in 24 hours.

Mounting:

- Compatible with drywall or drop ceiling mount installations. Bar hangers included.
- Wall mount capability optional.

Housing:

- Premium-grade, extruded aluminum housing.
- Extruded aluminum trim assembly is easily detachable from below, providing accessibility for service or maintenance. Available in optional black or white powder-coated finishes.
- Self-adhesive Chevron appliques and guide template provided for directional indication.

Options:

- WM: Allows for the unit to be wall recessed mounted.
- 2C-120V/2C-277V: Voltage-specific dual circuit option on the AC-only unit enables it to be connected to two different supplies at the same time.
- SDT: Self-diagnostic feature performs monthly, biannual, and annual tests to ensure reliable operation and meets electrical and life safety codes.
- USA: Substantial transformation assembly in the U.S. complies with “Assembled in the USA” under the Buy American Act.
- SPV: UL Listed for 208/220/240 Volt, 50/60Hz..
- Custom: Signs available with requested ‘special’ wording.

Project: _____

Date: _____

Catalog #: _____

Notes: _____

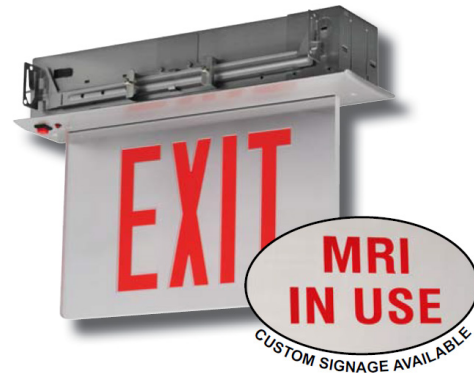

Warranty / Listing:

Five year warranty on all electronics and housing. Battery prorated for five years.
 Meets UL924, NFPA 101 Life Safety Code, NEC, OSHA, Local and State Codes.
 UL Listed for damp locations (0°C – 50°C).
 Certified to CEC under Title 20 Regulations.

Dimensions:

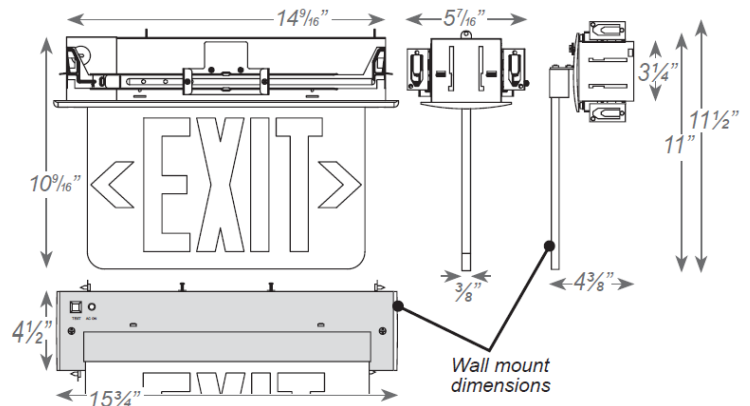

Catalog Data:

Sample Part Number: RELZXTE1RCWEM

| MODEL | No. of FACES | LETTER | PANEL | TRIM PLATE | BATTERY | OPTIONS | |
|---------|--------------|-------------|---------|----------------------|---------|-------------------|--|
| RELZXTE | 1 | Single Face | R Red | C Clear ¹ | W White | (blank) AC Only | WM Wall Mount ¹ |
| | 2 | Double Face | G Green | M Mirror | B Black | EM Battery Backup | 2C-120 Dual Circuit With 120V Input ² |
| | | | W White | A Aluminum | | | 2C-277 Dual Circuit With 277V Input ² |
| | | | | | | | SDT Self-Diagnostics ³ |
| | | | | | | | USA Assembled In USA |
| | | | | | | | SPV 208/220/240 Volt, 50/60Hz ⁴ |
| | | | | | | | CUSTOM Custom Wording |

¹ With single face only.
² Available only with AC units.
³ Available only with EM units.
⁴ Not available with SDT.

