

### Key Features & Benefits:

- Resistant to Shock and Vibration
- Emergency Back Up Capable
- IK10 Impact Rated
- ABS Certified
- Marine Rated Powder Coating
- Standard 10kV Surge Protection

Project: \_\_\_\_\_ Date: \_\_\_\_\_

Catalog #: \_\_\_\_\_

Notes: \_\_\_\_\_

### Product Specifications:

Power: 20–200 Watts  
 Lumen Output: Up to 28,000 Lumens  
 Efficacy (lm/W): Up to 140 Lumens per Watt  
 Kelvin: 3000K, 4000K, 5000K  
 CRI: >70  
 Power Frequency: 50/60Hz  
 Power Factor: >0.9  
 Operating Temperature: -40°F–140°F (-40°C–60°C)  
 Input Voltage: MV 120–277 VAC, HV 200–480 VAC, DC12–48V  
 Life Span: >150,000 Hours  
 Warranty: 7 Year Warranty with 10 Year Option  
 Product Weight:  
 15.43 lbs — Small  
 39.46 lbs — Large



### Certifications & Ratings:

Class I, Division 1, Groups C,D  
 Class I, Division 2, Groups A,B,C,D  
 Class II, Division 1, Groups E,F,G  
 Class II, Division 2, Groups F,G  
 Class III  
 UL 1598, UL 1598A — Standard for Luminaries for Installation on Marine Vessels  
 UL844 — Standard for Luminaries for Use in Hazardous Locations  
 IK10  
 ABS Certified  
 Marine Rating Powder Coated  
 IP66



### Ordering Guide:

ESL	TYPE	SIZE	WATTAGE	HAZARD LEVEL	KELVIN	INPUT VOLTAGE	BEAM ANGLE	OPTIONS
ESL	HZFL	(s)	(yy)W	1	(xx)	(zz)	(bb)	
	(HZFL) Hazardous Flood Light	(S) Small (L) Large	20W, 40W, 60W, 80W, 100W, 150W, 200W	(1) Class 1 Division 1	(30) 3000K (40) 4000K (50) 5000K	(Blank) MV 120–277 VAC (HV) 200–480 VAC (DC12) DC12–48V	(40D) (60D) (90D) (120D) Default	

### FACTORY INSTALLED OPTIONS

ESL-HZFL-S-TM-GR	Trunnion Mount for Small Flood Light, Grey Finish
ESL-HZFL-L-TM-GR	Trunnion Mount for Large Flood Light, Grey Finish
ESL-HZFL-ST-GR	Slip-fitter Mount /Stanchion, Grey Finish
ESL-HZFL-EMG	Emergency Back Up Unit for Hazardous Flood Light

**Catalog Data:**

ITEM#	WATTAGE	KELVIN (xx)	LUMENS	EFFICACY lm/W	INPUT VOLTAGE (zz)	DIMENSIONS (LxWxH)
ESL-HZFL-S20W-1xx-zz-bb	20W		2,800	140	(Blank) MV 120–277 VAC (DC12) DC12–48V	11.6"x11.6"x9.57"
ESL-HZFL-S40W-1xx-zz-bb	40W		5,600	140		
ESL-HZFL-S60W-1xx-zz-bb	60W	(30) 3000K (40) 4000K (50) 5000K	8,400	140		
ESL-HZFL-S80W-1xx-zz-bb	80W		11,200	140	(Blank) MV 120–277 VAC (HV) 200–480 VAC (DC12) DC12–48V	15.4"x11.2"x9.96"
ESL-HZFL-L100W-1xx-zz-bb	100W		14,000	140		
ESL-HZFL-L150W-1xx-zz-bb	150W		21,000	140		
ESL-HZFL-L200W-1xx-zz-bb	200W		28,000	140		

**Lighting Distribution:**

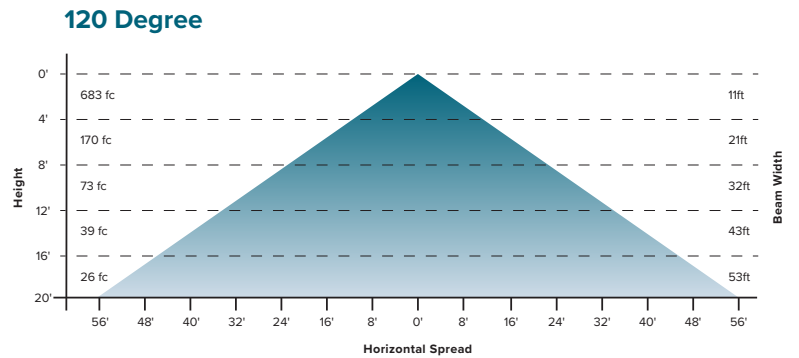
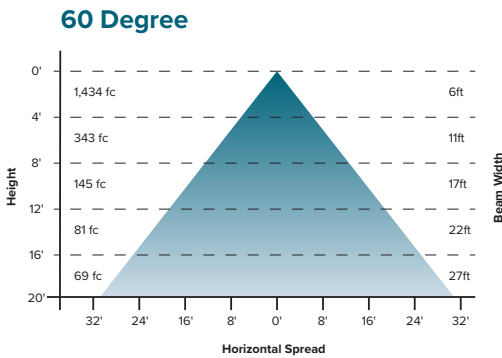
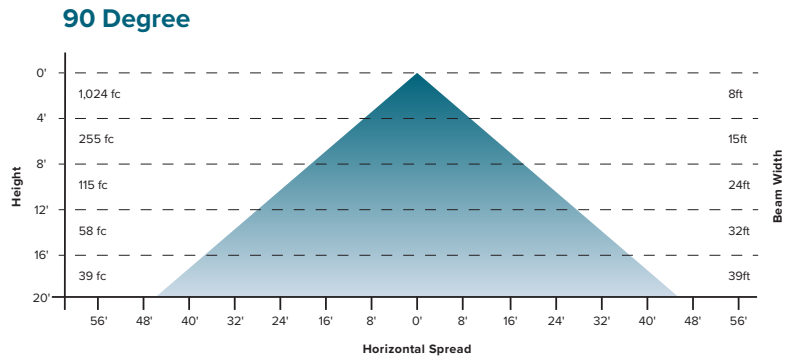
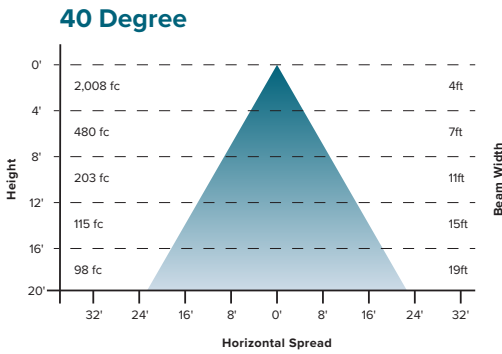

**Lumen Ambient Temperature (LAT) Multipliers:**

AMBIENT	LUMEN MULTIPLIER
0 °C 32 °F	1.02
10 °C 50 °F	1.01
20 °C 68 °F	1.00
25 °C 77 °F	1.00
30 °C 86 °F	1.00
40 °C 104 °F	0.99
50 °C 122 °F	0.96

**Fixture Dimensions:**

**Small**

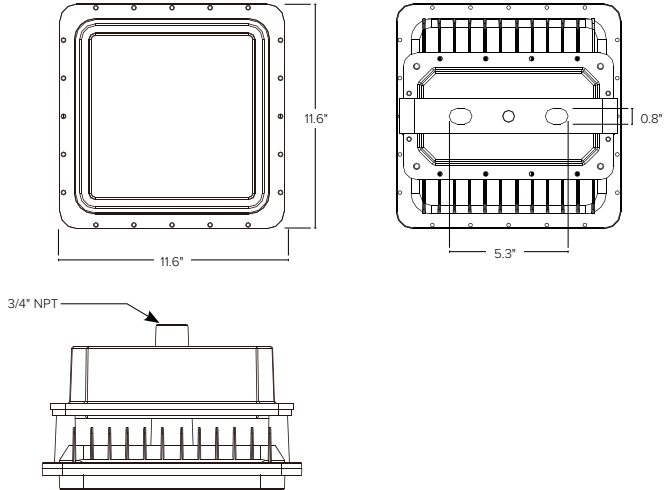

**Large**

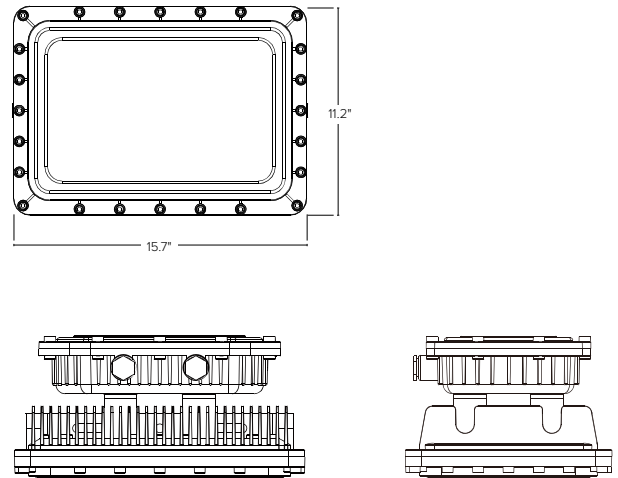

**Mounts:**

**Slip-Fitter/Stanchion Mount**

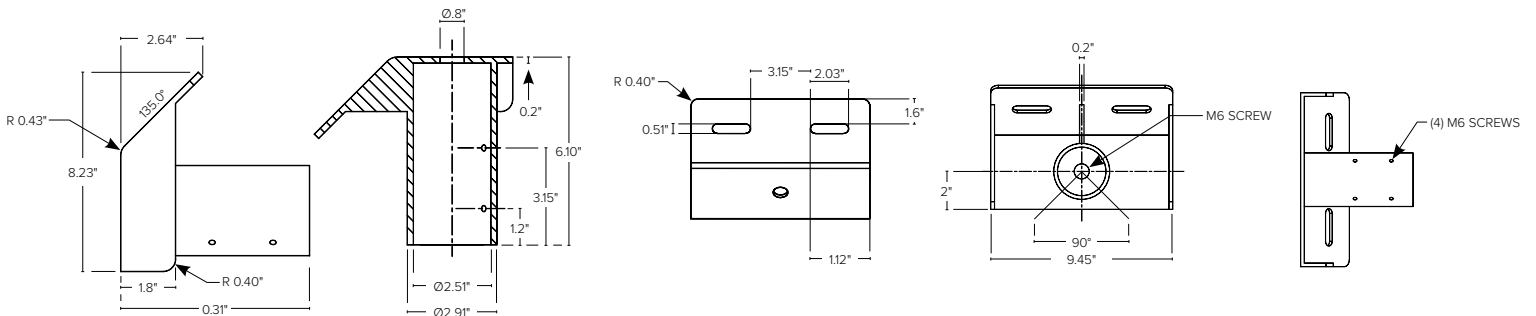

**Small Trunnion Mount**

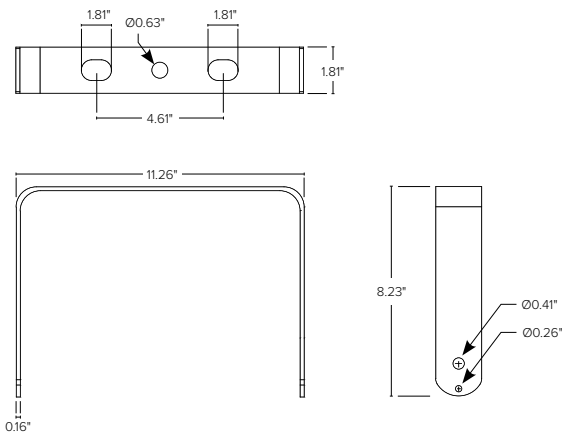

**Large Trunnion Mount**

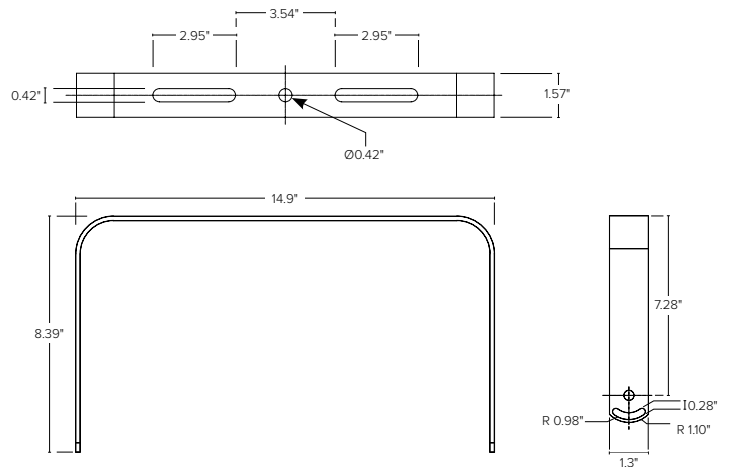

**Accessories:**

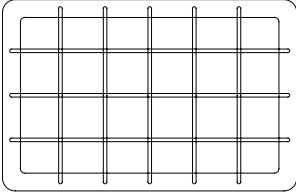

**Large Wire-Guard**  
ESL-HZFL-L-WG

**Small Wire-Guard**  
ESL-HZFL-S-WG

**Mounting Diagrams:**

**Ceiling Mount**

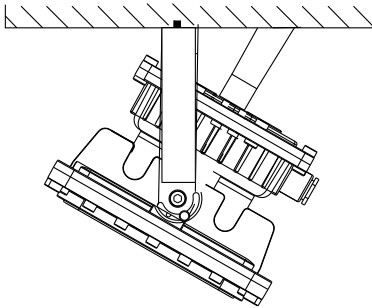

**Wall Mount**

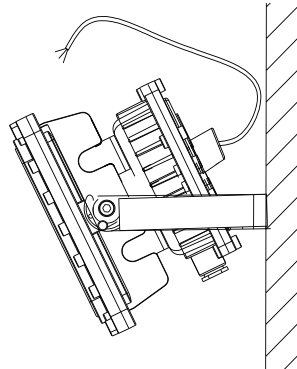

**Pole Mount**

