

⚠ WARNING

1. To avoid electric shock, disconnect power at source prior to installation.
2. The installation should be performed by qualified electricians or lighting technicians.
3. Before conducting any installation, maintenance, or removal, disable all power.
4. Do not touch the fixture while it is in service.
5. If there is any problem with the fixture, turn off power and DO NOT attempt repair unless you are a qualified technician or the customer service member.

Junction Box Mounting

1. Loosen the two (2) screws on the side of the housing to open fixture.
5. Set the kelvin & wattage to the desired levels.

2. Prepare the back plate for mounting by drilling or knocking out the appropriate holes. Refer to the backplate diagram section.
6. Close the door & tighten the two (2) screws on the side of the housing

3. Line up the back plate in the desired location and mount securely using mounting bolts. Caulk the bolt heads.

4. Complete the wiring to the supply wires & ground (refer to wiring diagrams).

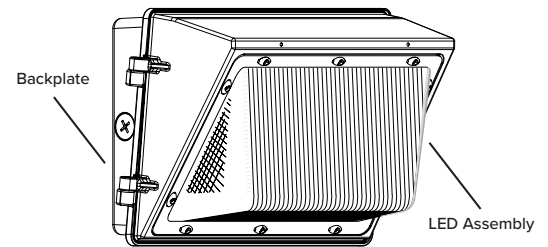

Electrical Wiring Diagram

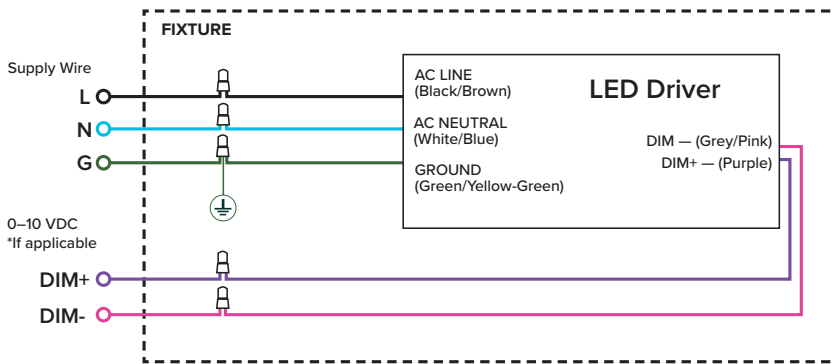

Backplate Diagram

- A — 5/16" dia. Knockouts
- B — 9/16" dia. Knockouts
- C — Knockouts for #10 screw
- D — 1/2" NPS tapped holes.

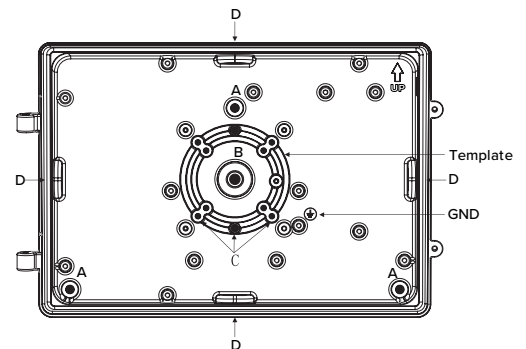

Electrical Wiring Diagram (With EM Backup)

