

Key Features & Benefits:

- Resistant to Shock and Vibration
- Emergency Back Up Capable
- IK10 Impact Rated
- ABS Certified
- Marine Rated Powder Coating
- Standard 10kV Surge Protection

Product Specifications:

Power: 20–400 Watts
 Lumen Output: Up to 56,000 Lumens
 Efficacy (lm/W): Up to 140 Lumens per Watt
 Kelvin: 3000K, 4000K, 5000K
 CRI: >70
 Power Frequency: 50/60Hz
 Power Factor: >0.9
 Operating Temperature: -40°F–140°F (-40°C–60°C)
 Input Voltage: MV 120–277 VAC, HV 200–480 VAC, DC12–48V
 Life Span: >150,000 Hours
 Warranty: 7 Year Warranty with 10 Year Option
 Product Weight:
 7.72 lbs — Small
 9.70 lbs — Medium
 18.08 lbs — Large
 41.45 lbs— Extra Large

Certifications & Ratings:

Class I, Division 2, Groups A,B,C,D
 Class II, Division 2, Groups F,G
 Class III
 UL 1598, UL 1598A — Standard for Luminaries for Installation on Marine Vessels
 UL844 — Standard for Luminaries for Use in Hazardous Locations
 IK10
 ABS Certified
 Marine Rating Powder Coated
 IP66

Project: _____ Date: _____
 Catalog #: _____
 Notes: _____



Ordering Guide:

ESL	TYPE	SIZE	WATTAGE	HAZARD LEVEL	KELVIN	INPUT VOLTAGE	BEAM ANGLE	GLASS LENS	OPTIONS
ESL	HZRHB	(sz)	(yy)W	2	(xx)	(zz)	(bb)	(gg)	
	(HZRHB) Hazardous Round High Bay	(S) Small (M) Medium (L) Large (XL) Extra Large	20W 40W 60W 80W 100W 120W	(2) Class 1 Division 2	(30) 3000K (40) 4000K (50) 5000K	(Blank) MV 120–277 VAC (HV) 200–480 VAC (DC12) DC12–48V	(40D) (60D) (90D) (120D) Default	(Blank) Flat (SG) Spherical Glass	

FACTORY INSTALLED OPTIONS

ESL-HZRHB-HOOK-GR	Pendent Mounting Hook, Grey Finish
ESL-HZ-WMJB-90D-GR	Wall Mounting to Junction Box 90 Degree, Grey Finish
ESL-HZ-WMJB-25D-GR	Wall Mounting to Junction Box 25 Degree, Grey Finish
ESL-HZRHB-EMG	Emergency Back Up Unit for Hazardous Round High Bay Series

INSTALLED ACCESSORIES

ESL-HZRHB2-S-ARF	Aluminum Reflector for Small Size
ESL-HZRHB2-M-ARF	Aluminum Reflector for Medium Size
ESL-HZRHB2-L-ARF	Aluminum Reflector for Large Size
ESL-HZRHB2-S-ARF-30D	30° cut off Aluminum Reflector for Small Size
ESL-HZRHB2-M-ARF-30D	30° cut off Aluminum Reflector for Medium Size
ESL-HZRHB2-L-ARF-30D	30° cut off Aluminum Reflector for Large Size

Catalog Data:

ITEM#	WATTAGE	KELVIN (xx)	LUMENS	EFFICACY lm/W	INPUT VOLTAGE	DIMENSIONS (LxWxH)
ESL-HZRHB-S20W-2xx-zz-bb-gg	20W		2,800	140	(Blank) MV 100–277VAC (DC12) DC12–48V	9.0"x9.0"x6.2"
ESL-HZRHB-S40W-2xx-zz-bb-gg	40W		5,600	140		
ESL-HZRHB-M60W-2xx-zz-bb-gg	60W		8,400	140		
ESL-HZRHB-M80W-2xx-zz-bb-gg	80W		11,200	140		
ESL-HZRHB-L100W-2xx-zz-bb-gg	100W		14,000	140	(Blank) MV 100–277VAC (HV) 200–480V (DC12) DC12–48V	10.6"x10.6"x6.1"
ESL-HZRHB-L120W-2xx-zz-bb-gg	120W		16,800	140		
ESL-HZRHB-L150W-2xx-zz-bb-gg	150W		21,000	140		
ESL-HZRHB-L200W-2xx-zz-bb-gg	200W		28,000	140		
ESL-HZRHB-XL250W-2xx-zz-bb-gg	240W		33,600	140		
ESL-HZRHB-XL300W-2xx-zz-bb-gg	280W		39,200	140		
ESL-HZRHB-XL400W-2xx-zz-bb-gg	400W		56,000	140		18.9"x18.9"x8.3"

Lighting Distribution:

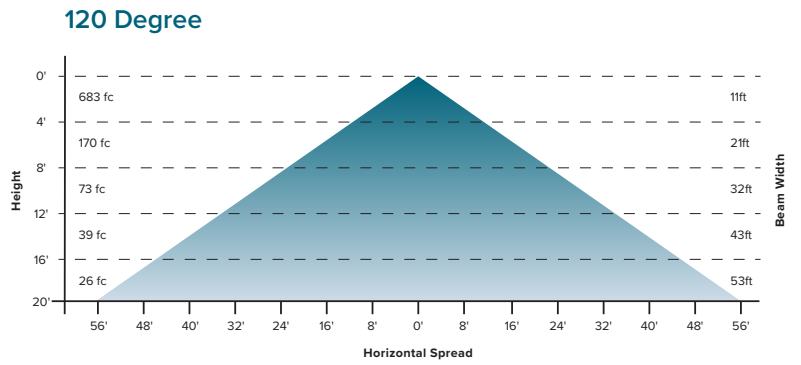
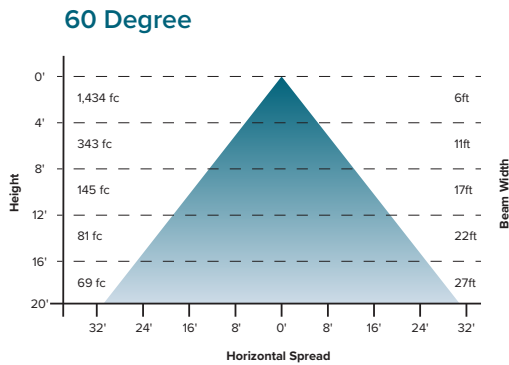
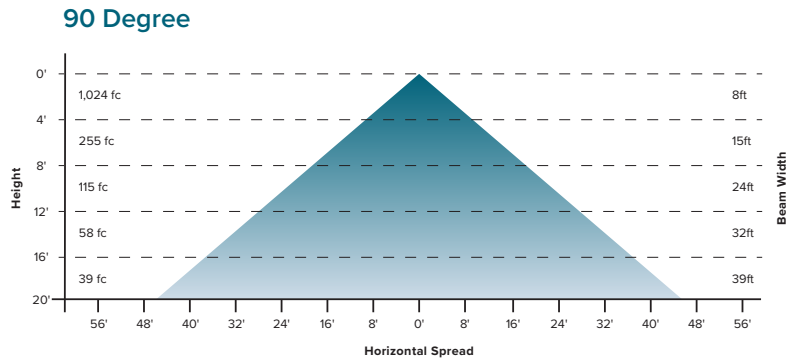
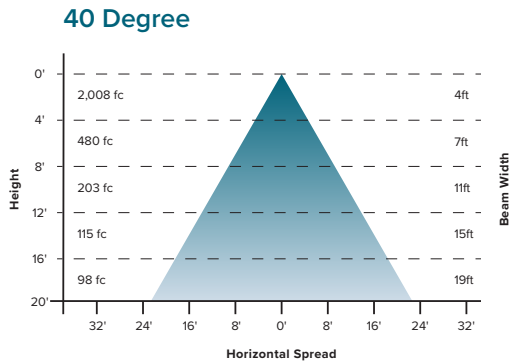

Lumen Ambient Temperature (LAT) Multipliers:

AMBIENT	LUMEN MULTIPLIER
0 °C 32 °F	1.02
10 °C 50 °F	1.01
20 °C 68 °F	1.00
25 °C 77 °F	1.00
30 °C 86 °F	1.00
40 °C 104 °F	0.99
50 °C 122 °F	0.96

Fixture Dimensions:

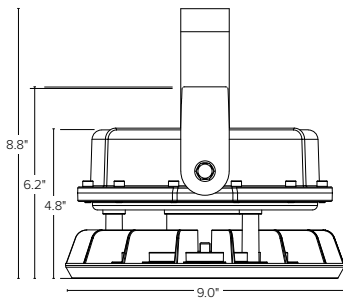

Small

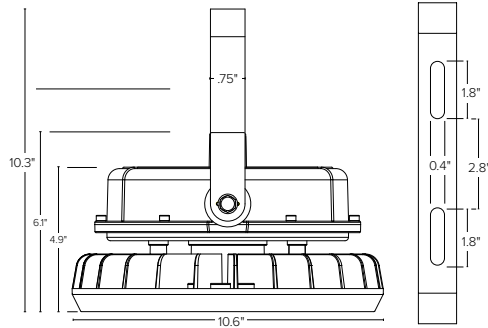

Medium

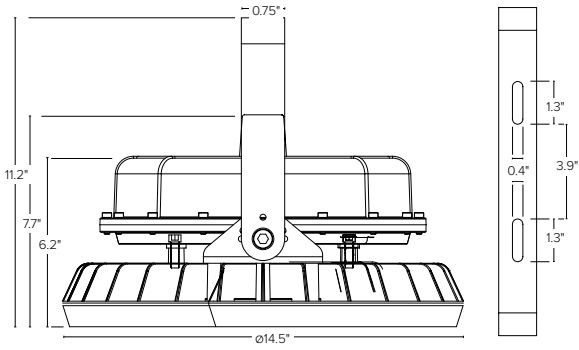

Large

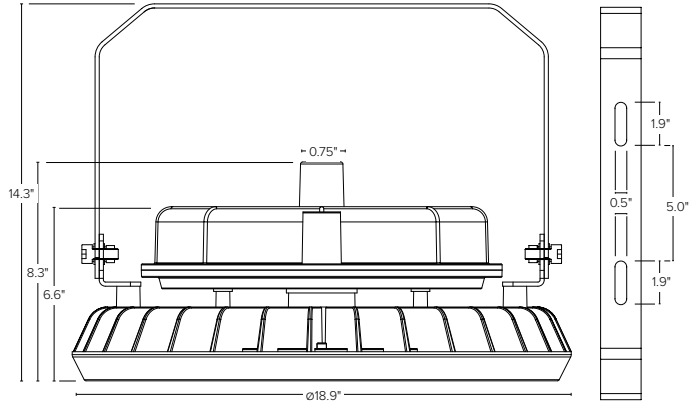

Extra Large

Flat LED Module & Lampshade

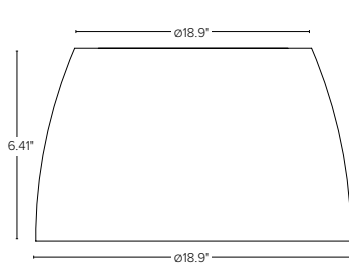

Small/Medium

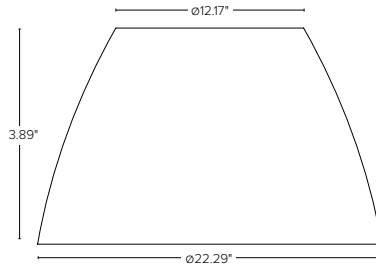

Large

Flat LED Module & 30° Cutoff Lampshade

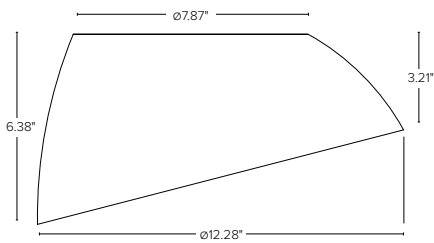

Small/Medium

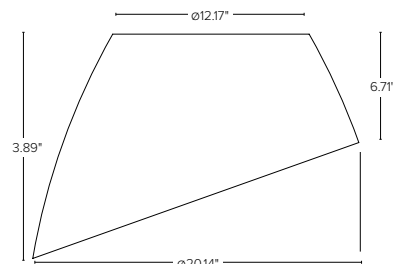

Large

Flat & 30° Lampshades Not Available on Extra Large Fixture

Mount Dimensions:

25° Wall Mount to Junction Box

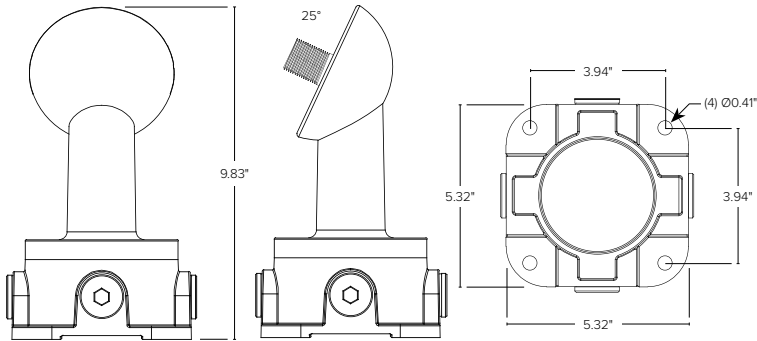

90° Wall Mount to Junction Box

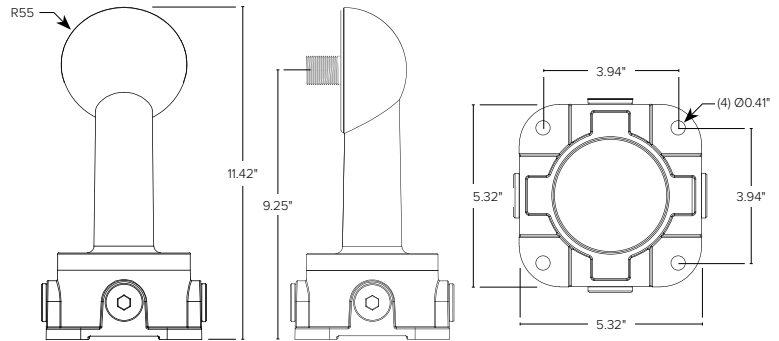

Junction Box

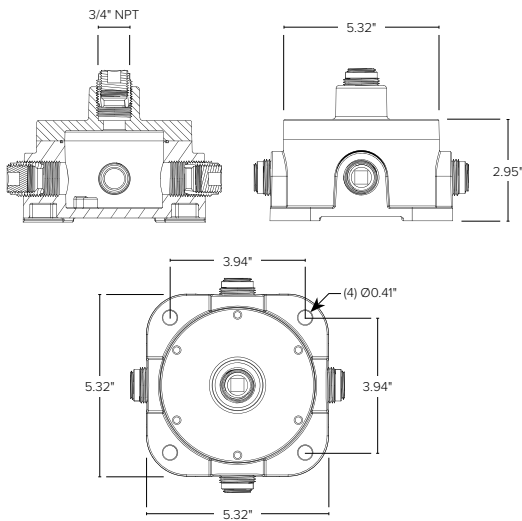

Pendant Hook

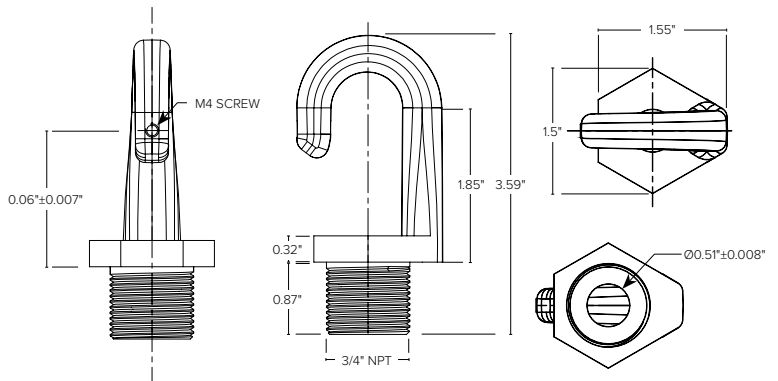

Accessories:

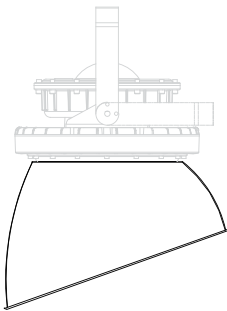

30° Cut Off Aluminum Reflector

ESL-HZRHB2-S-ARF-30D (Small)
ESL-HZRHB2-M-ARF-30D (Medium)
ESL-HZRHB2-L-ARF-30D (Large)
(Not Available in Extra Large)

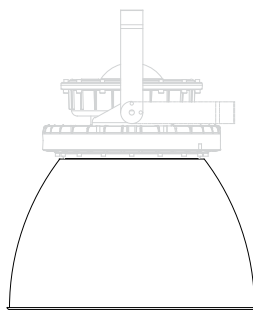

Aluminum Reflector

ESL-HZRHB2-S-ARF (Small)
ESL-HZRHB2-M-ARF (Medium)
ESL-HZRHB2-L-ARF (Large)
(Not Available in Extra Large)

Mounting Diagrams:

Ceiling Mounting

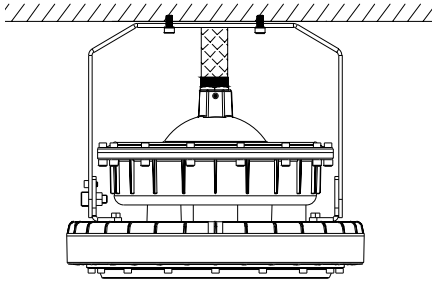

Hook Pendant Mounting

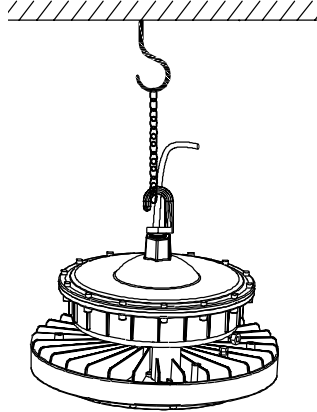

Hook Pendant Mounting

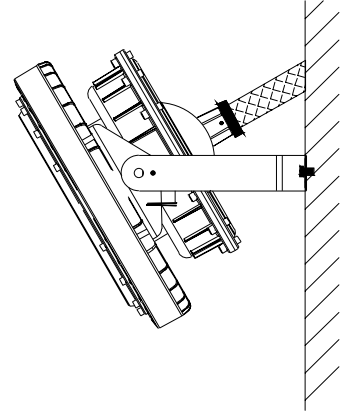

Wall Mounting to Junction Box

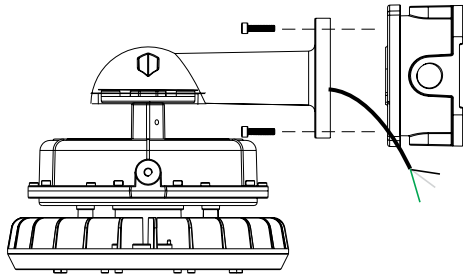

Pole Mounting

