

**IMPORTANT :** Read all instructions before installing fixtures. Retain for future reference.

**SAFETY :** For your safety, this fixture must be wired in accordance to local electrical codes and ordinances. All work should be done by a qualified electrician.

**WARNING :** Make certain power is OFF from the electrical panel before starting installation or attempting any maintenance.

Indoor installation only. Use on 120 VAC (Fig. 1)

60Hz circuits.

**TOOLS REQUIRED:**

- Saw
- Measuring Tape
- Electrical Wiring (use type and gauge suitable for application to connect the fixtures)

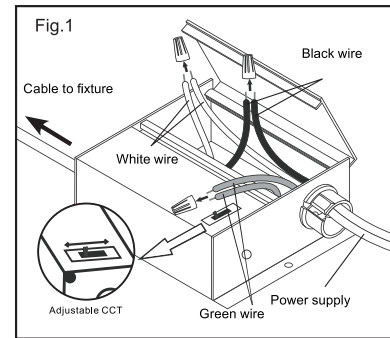

**PRE-INSTALLATION:**

1. Turn power OFF from the electrical panel before starting installation.
2. Locate a suitable position to plate the fixture and open in accordance to the cut-hole dimensions (refer to Hole Cut Table for appropriate size).
3. Run electrical wire from the switch (power supply) through the mounting hole-use NMD90 Romex or BX cable.

**DRIVER WIRING:**

1. Open the hardwire box swing cover and remove the appropriate knockout (s).
2. Insert the electrical supply cable through the knockout and secure with a cable connector (sold separately).
3. Make wiring connection to hardwire box.
  - a. Connect Black wire to line wire.
  - b. Connect White wire to neutral wire.
  - c. Connect Green wire to ground wire.
4. Place all wiring and connections back in to the box and close the cover.
5. Insert hardwire box through the mounting hole. (Fig.2) New construction applications: Hardwire box shall be firmly secured to studs, joists, or similar fixed structural units.  
Remodel applications: Do not require the hardwire box to be firmly secured after the mounting plates, studs, joists, or structural units have been concealed.

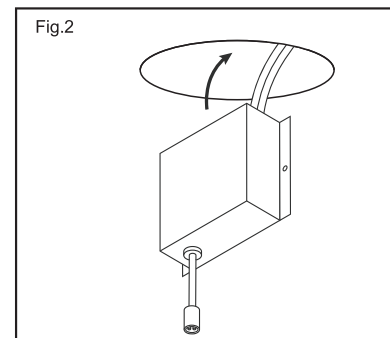

**FIXTURE INSTALLATION:**

1. Connect the fixture to the hardwire box by inserting and twisting the male/female connectors. (Fig.3)
2. Push spring loaded clips on the fixture upwards and insert fixture base in to the mounting hole. Release the clips and fixture will be pulled flush to the ceiling. (Fig.4)
3. Once assembly is complete, turn on power to confirm fixture is working properly.

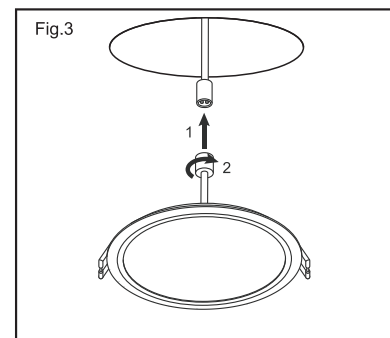

**FIXTURE INSTALLATION:**

1. Connect the fixture to the hardwire box by inserting and twisting the male/female connectors. (Fig.3)
2. Push spring loaded clips on the fixture upwards and insert fixture base in to the mounting hole. Release the clips and fixture will be pulled flush to the ceiling. (Fig.4)
3. Once assembly is complete, turn on power to confirm fixture is working properly.

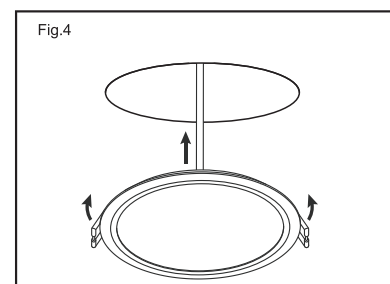

Hole Cut Size / Taille Trou Découpé	
4 inch round, 4 inch square	Ø4-1/4"(108mm)
6 inch round, 6 inch square	Ø6-1/4"(158mm)

