

### ⚠ WARNING

1. To avoid electric shock, disconnect power at source prior to installation.
2. The installation should be performed by qualified electricians or lighting technicians.
3. Before conducting any installation, maintenance, or removal, disable all power.
4. Do not touch the fixture while it is in service.
5. If there is any problem with the fixture, turn off power and **DO NOT** attempt repair unless you are a qualified technician or the customer service member.

### Retrofit Installation

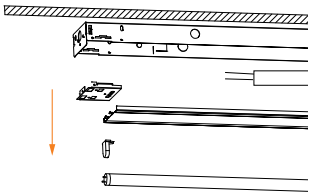

**1** Disconnect and remove the existing ballast cover, ballast, socket bars, and wiring.

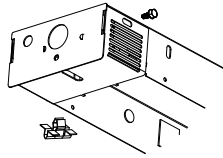

**2** Cut apart and install the included brackets as shown. For the 8ft fixture, use the larger center bracket to join the fixture halves.

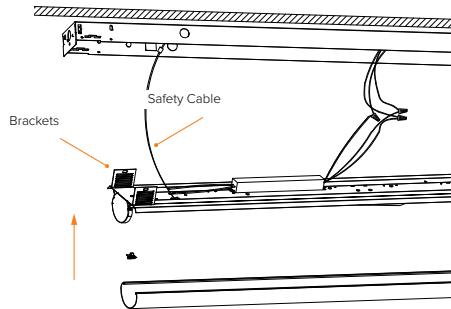

**3** Make electrical connections as shown in **Wiring Diagrams 1 and 2**. Install the LED retrofit assembly.

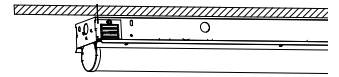

**4** Install optional lens. Restore power and turn on.

### Wiring Diagram 1

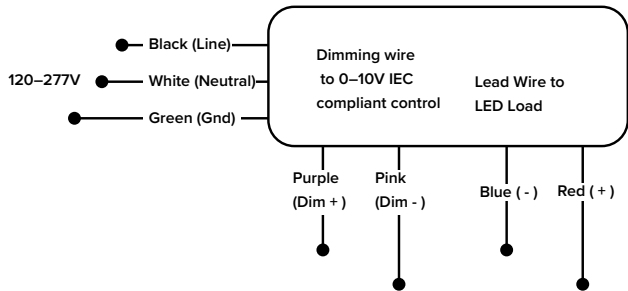

### Wiring Diagram 2

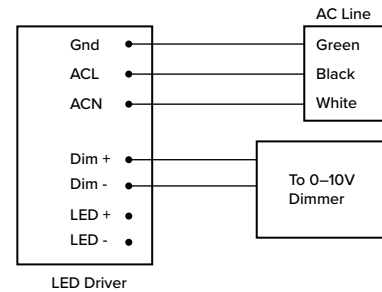

### Field Adjustable Wattage and CCT

**1** Kelvin and wattage can be adjusted using the dip switches located on the driver.

**2** Select the desired kelvin and wattage by sliding the dip switch.

