

! WARNING

1. To avoid the risk of fire or electric shock, disconnect power at the source prior to installation.
2. The installation should be performed by qualified electricians or lighting technicians.
3. To prevent damage, do not expose wiring to sheet metal edges or other sharp objects.
4. Do not make holes or alter the enclosure or components during kit installation.
5. If there is any problem with the fixture, turn off the power and **DO NOT** attempt repair unless you are a qualified technician or the customer service member.

6 Inch LED Retrofit Downlight:

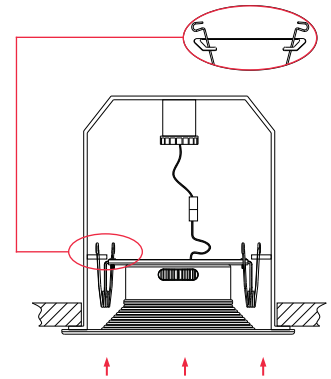
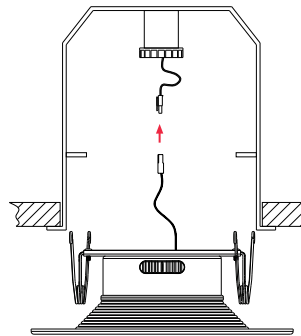
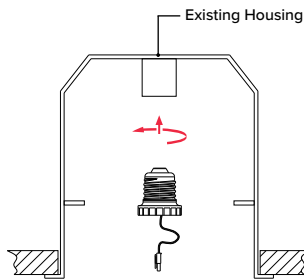
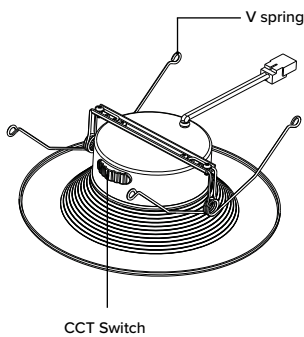

1 Set the CCT switch to your desired color temperature. If installing into a 5" housing adjust the V spring to suit. If installing into a 6" housing no adjustment is needed.

2 Thread the socket adapter into the socket.

3 Plug the female connector of the retrofit into the male connector of the socket adapter.

4 Squeeze the spring arms together and insert into the slots of the can. Tuck all wires into the can and carefully push the retrofit downlight into the can housing.

4 Inch LED Retrofit Downlight:

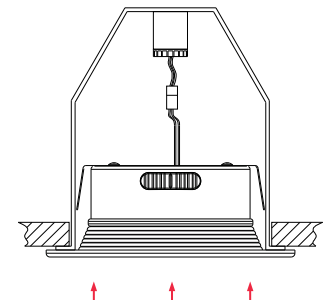
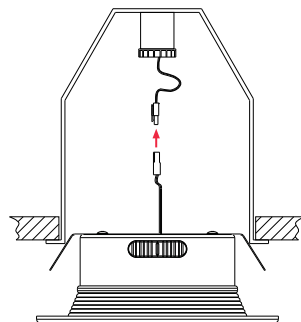
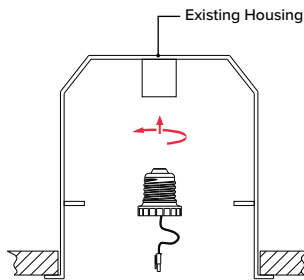
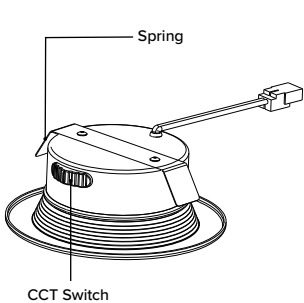

1 Set the CCT switch to your desired color temperature.

2 Thread the socket adapter into the socket.

3 Plug the female connector of the retrofit into the male connector of the socket adapter.

4 Squeeze both spring arms together and insert into the slots of the can. Tuck all wires into the can and carefully push the retrofit downlight into the can housing.