

Key Features & Benefits:

- PIR Occupancy Sensor
- Kelvin and Wattage Selectable
- Built-In Patent-Pending Replaceable Photocell
- UV Polycarbonate Optic Lens
- 10kV Surge Protector

Product Specifications:

Selectable Wattage: 100W–125W–160W
 Selectable Kelvin: 3000K–4000K–5000K
 Lumens: Up to 19,400
 Efficacy: Up to 126 lm/W
 Input Voltage: 120–277 VAC
 Input Frequency: 50/60 Hz
 Operating Temperature: -40°F to 104°F (-40°C to 40°C)
 Dimming: 0–10V
 CRI: >70
 Warranty: 7 Years
 L70 Lifetime 90,000 Hours calculated per TM21
 Dimensions (LxWxH): 17.3" x 22.2" x 4.52"
 Weight (lbs): 26.46

Project: _____ Date: _____
 Catalog #: _____
 Notes: _____



Ordering Guide:

ESL	TYPE	SELECTABLE WATTAGE	GENERATION	SELECTABLE KELVIN	FINISH	OPTIONS
ESL	PT (PT) Post Top	100160W (100160W) 100W–125W–160W	1 (1) 1st Generation	3050 (3050) 3000K–4000K–5000K	BZ (BZ) Bronze	

FACTORY INSTALLED OPTIONS

RPC7 7 Pin Twist Lock Receptacle for Wireless Control – Contact your Rep for More Information on Wireless Control

Catalog Data:

ITEM#	SELECTABLE WATTAGE	SELECTABLE KELVIN	MAX LUMEN OUTPUT	MAX EFFICACY (lm/w)	DIMENSIONS (LxWxH)	DLC QPL CODE
ESL-PT-4580W-13050	45W–60W–80W	3000K–4000K–5000K	9,700	126	17.3" x 22.2" x 4.52"	S-ZK1JBG
ESL-PT-100160W-13050	100W–125W–160W	3000K–4000K–5000K	19,400	126	17.3" x 22.2" x 4.52"	S-NGPXG9

Lumen Ambient Temperature (LAT) Multipliers:

AMBIENT	LUMEN MULTIPLIER
0 °C 32 °F	1.02
10 °C 50 °F	1.01
20 °C 68 °F	1.00
25 °C 77 °F	1.00
30 °C 86 °F	1.00
40 °C 104 °F	0.99
50 °C 122 °F	0.96

Photometrics:

LEGEND

- 20 fc
 - 10 fc
 - 5 fc
 - 1 fc
 - 0.5 fc
 - 0.1 fc
 - 50% Max Cd
 - Max Cd
- Distances are based on units of 25' mounting height

Decorative Post Top
ESL-PT-4580W-13050-BZ
(based on 80W and 4000K)

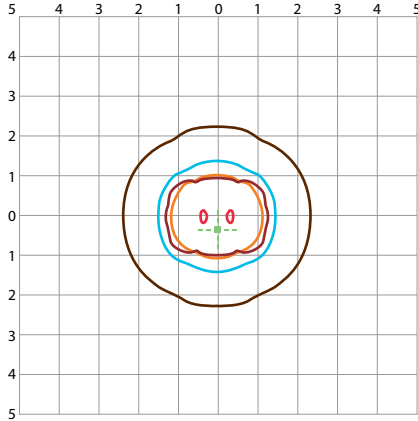

ESL-PT-100160W-13050-BZ
(based on 160W and 4000K)

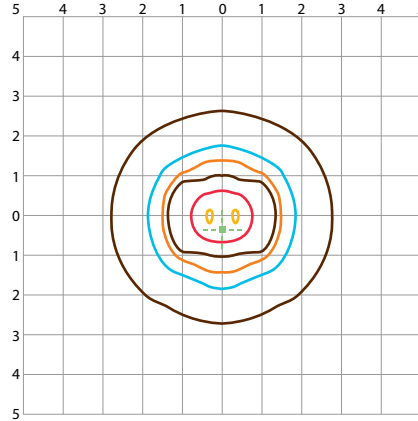

LCS Table

Decorative Post Top

ESL-PT-4580W-13050-BZ – BUG Rating: B3–U3–G2
(based on 80W and 4000K)

	BUG Rating	Lumens	Lumens%
Forward Light	Low (0–30)	1,347.0	13.9%
	Medium (30–60)	2,542.3	26.2%
	High (60–80)	823.3	8.5%
	Very High (80–90)	108.5	1.1%
Back Light	Low (0–30)	1,347.0	13.9%
	Medium (30–60)	2,542.3	26.2%
	High (60–80)	823.3	8.5%
	Very High (80–90)	108.5	1.1%
Uplight	Low (90–100)	64.8	0.7%
	High (100–180)	0	0%
Trapped Light		3.1	0%

ESL-PT-100160W-13050-BZ – BUG Rating: B4–U3–G2
(based on 160W and 4000K)

	BUG Rating	Lumens	Lumens%
Forward Light	Low (0–30)	2,672.1	13.8%
	Medium (30–60)	5,129.4	26.4%
	High (60–80)	1,615.5	8.3%
	Very High (80–90)	215.2	1.1%
Back Light	Low (0–30)	2,672.1	13.8%
	Medium (30–60)	5,129.4	26.4%
	High (60–80)	1,615.5	8.3%
	Very High (80–90)	215.2	1.1%
Uplight	Low (90–100)	130.4	0.7%
	High (100–180)	0	0%
Trapped Light		5.1	0%

Mounting Options:

Standard Installation

ESL-PT-4580W-13050-BZ &
ESL-PT-100160W-13050-BZ

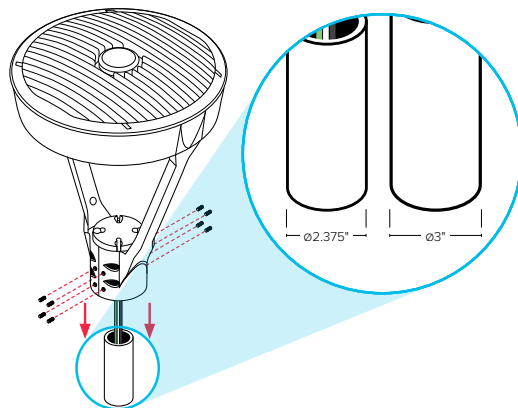

This fixture is intended to be mounted on a heavy-duty pipe or tenon with a maximum outer dimension of 2³/₈" (60mm) with inner sleeve in place. Inner sleeve can be removed and this maximum outer dimension increases to accommodate a 3" (76.2mm) pipe or tenon.

Dimensions:

Decorative Post Top
ESL-PT-4580W-13050-BZ &
ESL-PT-100160W-13050-BZ

