

### Key Features & Benefits:

- Kelvin and Wattage Selectable
- Built-In Patent-Pending Replaceable Photocell
- Durable Polycarbonate Lens
- Die-cast Aluminum Heat Sink

Project: \_\_\_\_\_ Date: \_\_\_\_\_  
 Catalog #: \_\_\_\_\_  
 Notes: \_\_\_\_\_

### Product Specifications:

Selectable Wattage: 10W—20W—30W  
 Selectable Kelvin: 3000K—4000K—5000K  
 Lumens: Up to 4,500  
 Efficacy: Up to 148 lm/W  
 Input Voltage: 120–277 VAC  
 Input Frequency: 50/60 Hz  
 Operating Temperature: -40°F to 104°F (-40°C to 40°C)  
 Dimming: 0–10V  
 CRI: >70  
 Warranty: 7 Years  
 L70 Lifetime 90,000 Hours calculated per TM21  
 Dimensions (LxWxH): 11.39" x 7.55" x 4.35"  
 Weight (lbs): 4.41

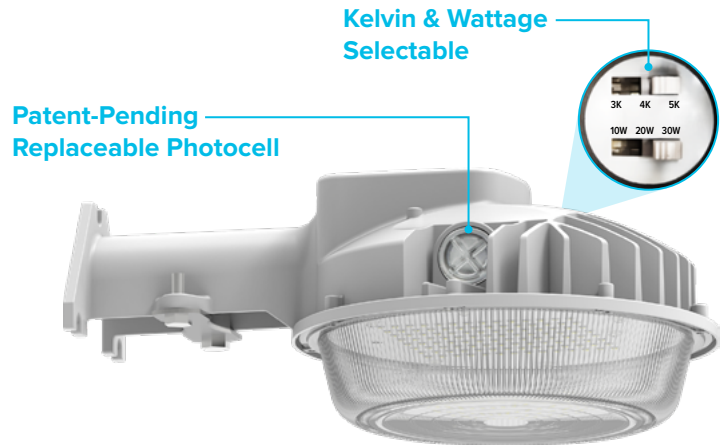

### Ordering Guide:

ESL	TYPE	SELECTABLE WATTAGE	GENERATION	SELECTABLE KELVIN	FINISH
ESL	D2D <small>(D2D) Dusk to Dawn Barn Light</small>	1030W <small>(1030W) 10W–20W–30W</small>	1 <small>(1) 1st Generation</small>	3050 <small>(3050) 3000K–4000K–5000K</small>	SL <small>(SL) Silver</small>

### Catalog Data:

ITEM#	SELECTABLE WATTAGE	SELECTABLE KELVIN	MAX LUMEN OUTPUT	MAX EFFICACY (lm/w)	DIMENSIONS (LxWxH)
ESL-D2D-1030W-13050-SL	10W–20W–30W	3000K–4000K–5000K	4,500	148	11.39" x 7.55" x 4.35"
ESL-D2D-4080W-13050-SL	40W–60W–80W	3000K–4000K–5000K	11,000	148	13.9" x 10" x 5.2"

### Lumen Ambient Temperature (LAT) Multipliers:

AMBIENT	LUMEN MULTIPLIER
0 °C 32 °F	1.02
10 °C 50 °F	1.01
20 °C 68 °F	1.00
25 °C 77 °F	1.00
30 °C 86 °F	1.00
40 °C 104 °F	0.99
50 °C 122 °F	0.96

### Dimensions:

Dusk to Dawn Barn Light – Low Wattage  
ESL-D2D-1030W-13050-SL

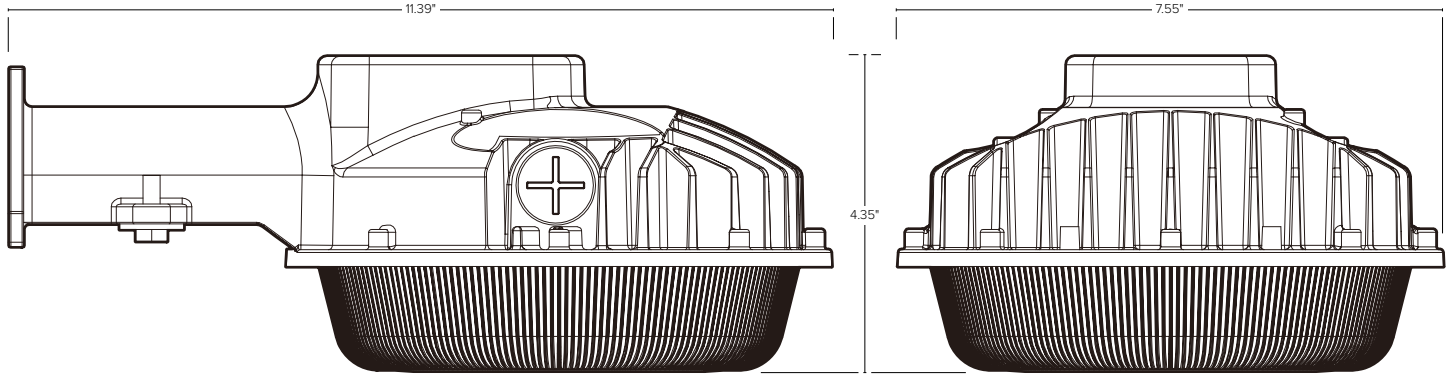

Dusk to Dawn Barn Light – High Wattage  
ESL-D2D-4080W-13050-SL

