

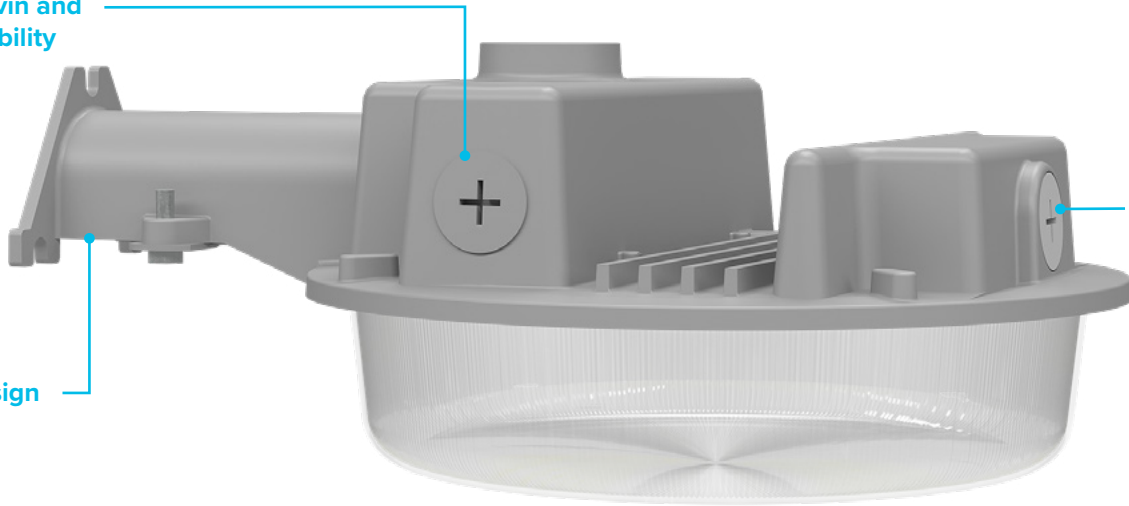

DUSK 2 DAWN BARN LIGHT

Introducing the Dusk 2 Dawn from ESL Vision: the ultimate cost-effective, reliable outdoor area and security lighting solution. Featuring Selectable Kelvins, two Wattage Selectable sizes and a multi-mount design allowing for easy wall or pole mounting, the D2D offers unmatched flexibility. With it's rugged build, superior light distribution and robust weather protection it's the perfect blend of efficiency and reliability—from dusk 'til dawn.

Easy Access Kelvin and Wattage Selectability



On/Off Serviceable Photocell

Multi-Mount Design

ESL-D2D-4060W

Flexible and High-Efficiency

- Multi-Watt Selectable
 - 40W–60W–80W
 - 10W–20W–30W
- 3CCT Selectable Kelvin
 - 3000K–4000K–5000K
- 0–10V Dimmable
- Up to 148 lm/W
- Die-Cast Aluminum Body
- Wet Listed / IP65 Rated

Die-Cast Aluminum Heatsink for Ideal Heat Dissipation.

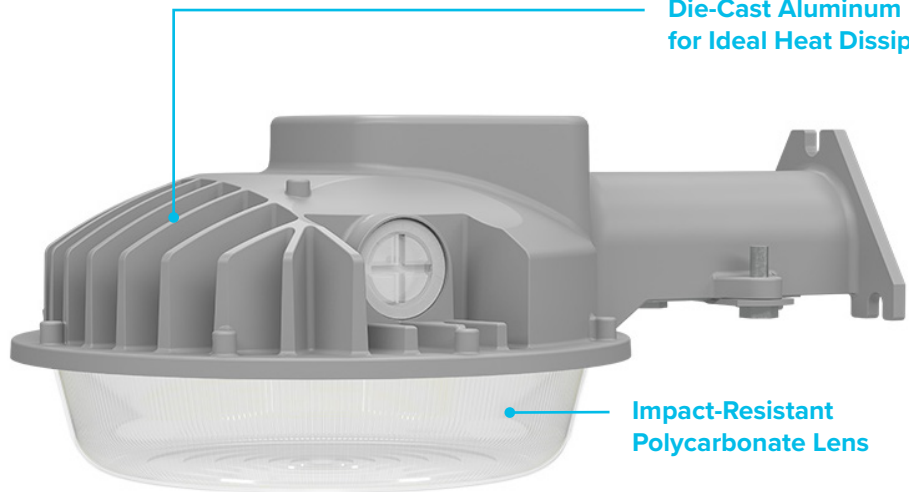

Impact-Resistant Polycarbonate Lens

ESL-D2D-1030W



*Not All Part Numbers DLC Qualified. For a Complete Listing Please Consult the DLC Qualified Products List (QPL).

Copyright ©2024 ESL Vision, LLC. All rights reserved. CAT# ESL-MKTG-SS-[prod]-[yymm] Rev. 09/19/24

COMPLETE COVERAGE—FROM SUNDOWN TO THE BREAK OF DAWN

Designed with flexibility in mind, the Dusk 2 Dawn is available in two sizes, each of which can be easily mounted on walls or poles, adapting to your specific needs. Its advanced lighting distribution technology ensures even, reliable coverage, guaranteeing consistent lighting all night long.

Multi-Mount:



Wall Mounted



Pole Mounted

Lighting Coverage:

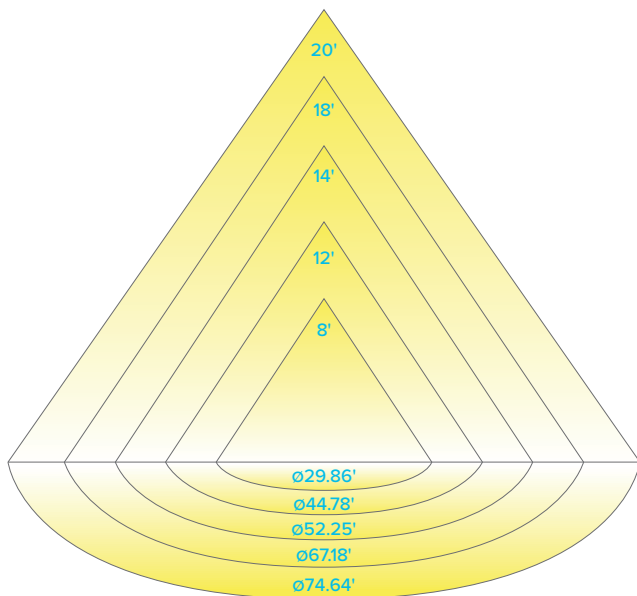

4080W

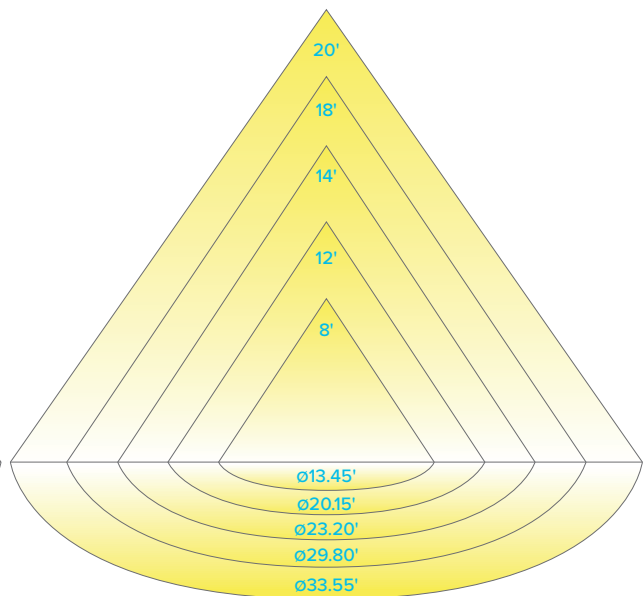

1030W

